

# SIGLENT TECHNOLOGIES

## RF PRODUCT CATALOG

- Spectrum Analyzer
- Spectrum & Vector Network Analyzer
- Vector Network Analyzer
- RF/MW Signal Generator



# CATALOG

<b>Company Profile</b> .....	02
<b>Vector Network Analyzer</b>	
SNA5000A Vector Network Analyzer .....	03
SHN900A Portable Vector Network Analyzer .....	08
<b>Switch Matrix</b>	
SSM5000A Switch Matrix .....	12
<b>Mechanical Switch</b>	
SSU5000A Mechanical Switch .....	14
<b>Spectrum Analyzer</b>	
SSA5000A Spectrum Analyzer .....	16
SSA3000X-R Real-time Spectrum Analyzer .....	19
SSA3000X Plus Spectrum Analyzer .....	23
SSA3000X Spectrum Analyzer .....	26
SHA850A Portable Spectrum Analyzer .....	29
<b>Spectrum &amp; Vector Network Analyzer</b>	
SVA1000X Spectrum & Vector Network Analyzer .....	32
<b>RF/MW Signal Generator</b>	
SSG6000A RF Signal Generator .....	36
SSG5000A RF Signal Generator .....	39
SSG5000X RF Signal Generator .....	41
SSG3000X RF Signal Generator .....	46
<b>Accessories</b> .....	50
<b>Other Products Overview</b> .....	55
<b>Service</b> .....	59

# Company Profile

SIGLENT TECHNOLOGIES Co., Ltd.

**Every Bench. Every Engineer. Every Day.**

**SIGLENT** has been providing test & measurement solutions for almost 18 years from its headquarter in Shenzhen, China. There are more than 300 employees, one third of whom are high-educated R&D engineers.

**SIGLENT** has many patent technologies. We are dedicated to develop sophisticated and high quality digital oscilloscopes, waveform generators, RF signal generators, handheld digital oscilloscopes, spectrum analyzers, vector network analyzers and DC power supplies, DC Electronic Loads, digital multimeters. We strive to deliver the highest quality of customer service and satisfaction to our customers.



## **SIGLENT** provides the following instruments:

- Digital Oscilloscope
- Handheld Oscilloscope
- Waveform Generator
- RF/MW Signal Generator
- Spectrum Analyzer
- Vector Network Analyzer
- DC Power Supply
- DC Electronic Load
- Digital Multimeter
- Probes & Accessories

**SIGLENT** sincerely invite you to join

Please email :

[sales@siglent.com](mailto:sales@siglent.com)

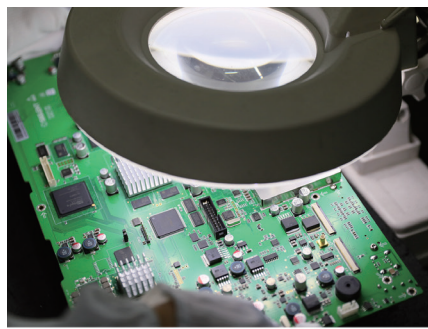



# SNA5000A

## Vector Network Analyzer



### Features and Benefits

- Frequency range: 9 kHz~8.5 GHz and 100 kHz~26.5 GHz
- Frequency resolution: 1 Hz
- Level resolution: 0.05 dB
- Range of IFBW: 10 Hz~3 MHz
- Setting range of output level: -55 dBm~+10 dBm
- Dynamic range: 125 dB
- Types of calibration: Response calibration, Enhanced Response calibration, Full-one port calibration, Full-two port calibration, Full-three port calibration, Full-four port calibration, TRL calibration
- Types of measurement: Scattering-parameter measurement, differential-parameter measurement, receiver measurement, time-domain parameter analysis, limit test, ripple test, impedance conversion, fixture simulation, adapter removal/insertion, spectrum analysis frequency offset, scalar mixer measurement
- Support Bias-Tees
- Interface: LAN, USB Device, USB Host(USB-GPIB)
- Remote control: SCPI/Labview/IVI based on USB-TMC/VXI-11/Socket/Telnet/WebServer
- 12.1-inch touch screen
- Video output: HDMI

 Design features

• Multi-window display



• Multi-format display



• Display and compare memory and current data



• Display data hold



• Impedance conversion



• Equation Editor

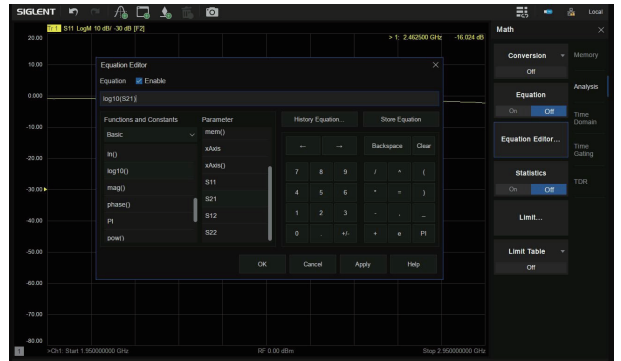

## • Port Extensions

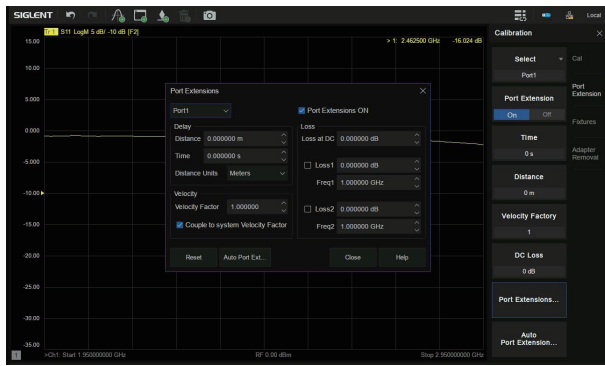

## • Embedding and De-Embedding

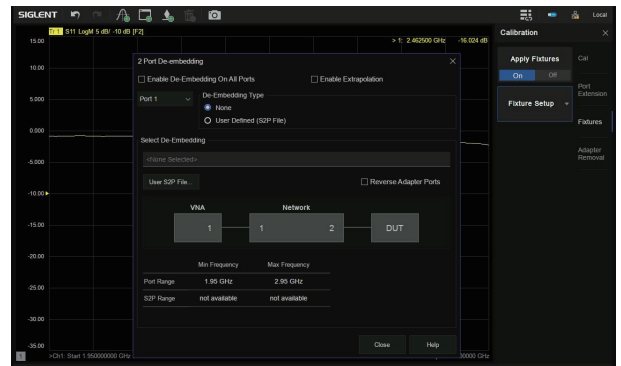

## • Time-Domain analysis

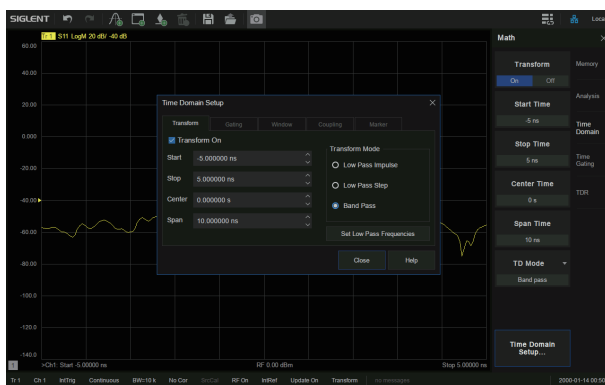

## • Enhanced Time-Domain analysis(TDR)



## • Spectrum analysis

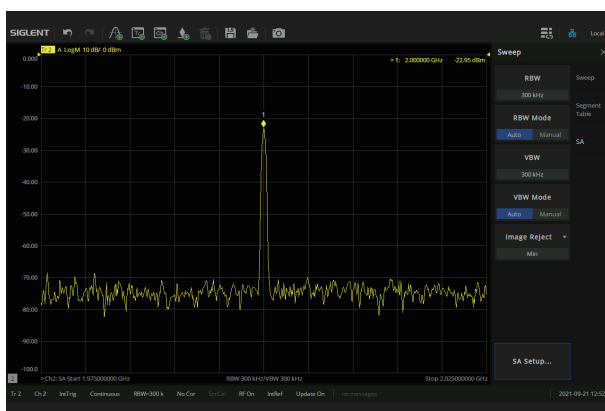

## • Scalar mixer measurement

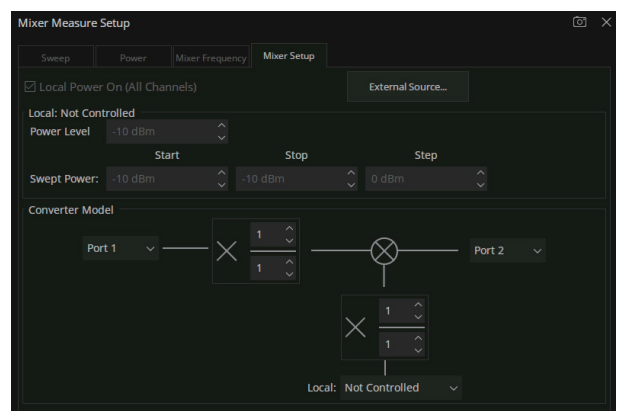



## Model and Main index

Model	SNA5002A SNA5004A	SNA5012A SNA5014A	SNA5022A	SNA5032A
Frequency range	9 kHz~4.5 GHz	9 kHz~8.5 GHz	100 kHz~13.5 GHz	100 kHz~26.5 GHz
Ports	2/4	2/4	2	2
Frequency resolution	1 Hz			
Level resolution	0.05 dB			
Range of IFBW	10 Hz~3 MHz			
Setting range of output level	-55 dBm ~ +10 dBm			
Dynamic range	125 dB			
Types of calibration	Response calibration, Enhanced Response calibration, Full-one port calibration, Full-two port calibration, Full-three port calibration, Full-four port calibration, TRL calibration			
Types of measurement	Scattering-parameter measurement, differential-parameter measurement, receiver measurement, time-domain parameter analysis, limit test, ripple test, impedance conversion, fixture simulation, adapter removal / insertion, enhanced time-domain parameter analysis (TDR), spectrum analysis, frequency offset, scalar mixer measurement			
Bias-Tees	Support			
Interface	LAN, USB Device, USB Host(USB-GPIB)			
Remote control	SCPI/Labview/IVI based on USB-TMC/VXI-11/Socket/Telnet/WebServer			
Display	12.1-inch touch screen			
Video output	HDMI			



## Ordering Information

Items	Description	Order Number
Products	2 ports, 4.5G Vector Network Analyzer	SNA5002A
	2 ports, 8.5G Vector Network Analyzer	SNA5012A
	4 ports, 4.5G Vector Network Analyzer	SNA5004A
	4 ports, 8.5G Vector Network Analyzer	SNA5014A
	2 ports, 13.5G Vector Network Analyzer	SNA5022A
	2 ports, 26.5G Vector Network Analyzer	SNA5032A
Standard Accessories	One Quick-start, One Power-cable, One USB-cable, One Calibration-certificate	
Optional Accessories	High-performance reference source	SNA5000-HPR
	Time-Domain analysis	SNA5000-TDA
	Enhanced Time-Domain analysis	SNA5000-TDR
	Spectrum analysis	SNA5000-SA
	Scalar mixer measurement	SNA5000-SMM
	N-type, Male, 50Ω Calibration Kit, 0~4.5 GHz	F503ME
	N-type, Female, 50Ω Calibration Kit, 0~4.5 GHz	F503FE
	3.5 mm, Male, 50Ω Calibration Kit, 0~4.5 GHz	F603ME
	3.5 mm, Female, 50Ω Calibration Kit, 0~4.5 GHz	F603FE
	N-type, Male, 50Ω Calibration Kit, 0~9 GHz	F504MS
	N-type, Female, 50Ω Calibration Kit, 0~9 GHz	F504FS

Items	Description	Order Number
Optional Accessories	N-type, Male and Female, 50Ω Calibration Kit, 0~9 GHz	F504TS
	3.5 mm, Male, 50Ω Calibration Kit, 0~9 GHz	F604MS
	3.5 mm, Female, 50Ω Calibration Kit, 0~9 GHz	F604FS
	3.5 mm, Male and Female, 50Ω Calibration Kit, 0~9 GHz	F604TS
	3.5 mm, Male and Female, 50Ω Calibration Kit, 0~27 GHz	F604TY
	N(M)-SMA(M) RF Cable DC~18 GHz, 1000 mm	N-SMA-18L
	N(M)-N(M) RF Cable DC~18 GHz, 1000 mm	N-N-18L
	SMA(M)-SMA(M) RF Cable DC~18 GHz, 1000 mm	SMA-SMA-18L
	SMA(M)-SMA(M) RF Cable DC~26.5 GHz, 1000 mm	SMA-SMA-26L
	SMA(F)-SMA(M) RF Cable DC~26.5 GHz, 1000 mm	SMAF-SMA-26L
	NMD 3.5 female-NMD 3.5 Male DC~26.5 GHz, 635 mm	V26-N35MN35F-25IN
	NMD 3.5 female-APC 3.5 female DC~26.5 GHz, 635 mm	V26-N35FA35F-25IN
	USB-GPIB Adapter	USB-GPIB
	VNA Options	2 ports, 9 kHz ~ 4.5 GHz, SMA female
2 ports, 9 kHz ~ 9 GHz, SMA female		SEM5012A
2 ports, 100 kHz ~ 13.5 GHz, 3.5 mm female		SEM5022A
2 ports, 100 kHz ~ 26.5 GHz, 3.5 mm female		SEM5032A
4 ports, 9 kHz ~ 4.5 GHz, SMA female		SEM5004A
4 ports, 9 kHz ~ 9 GHz, SMA female		SEM5014A
4 ports, 100 kHz ~ 13.5 GHz, 3.5 mm female		SEM5024A
4 ports, 100 kHz ~ 26.5 GHz, 3.5 mm female		SEM5034A





# SHN900A

## Portable Vector Network Analyzer

### Features and Benefits

- Standard VNA and CAT mode, Optional SA mode
- Frequency range: 30 kHz - 26.5 GHz
- Frequency resolution: 1 Hz
- Level resolution: 0.05 dB
- Range of IFBW: 10 Hz~3 MHz
- Setting range of output level: -45 dBm ~ +10 dBm
- Dynamic range: 110 dB(Typ.)
- Types of calibration: Response calibration, Enhanced Response calibration, Full-one port calibration, Full-two port calibration, TRL calibration
- Types of measurement: Scattering-parameter measurement, differential-parameter measurement, receiver measurement, time-domain parameter analysis, limit test, ripple test, impedance conversion, fixture simulation, adapter removal/insertion, spectrum analysis frequency offset, scalar mixer measurement, pulse measurement
- Internal Bias-Tee connections
- Support GPS, Time and Location Information Saving
- Interface: LAN, USB Device, USB Host (USB-GPIB)
- Remote control: SCPI/ Labview/ IVI based on USB-TMC / VXI-11 / Socket /Telnet / WebServer
- 8.4-inch touch screen, Mouse, Keyboard
- Typical working time 4 hours, 3.2 kg net weight

## Design features

### Multi-window display

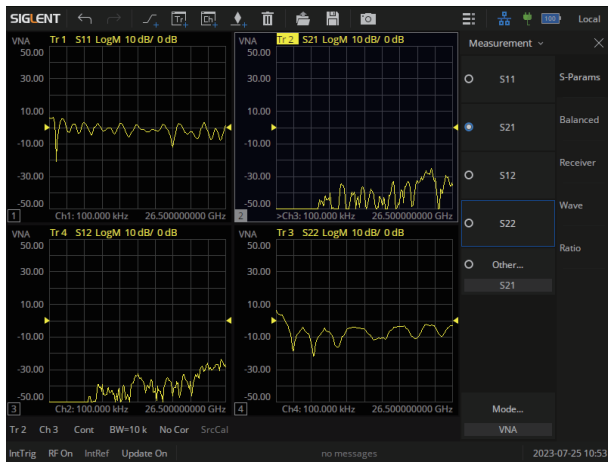

### Multi-format display

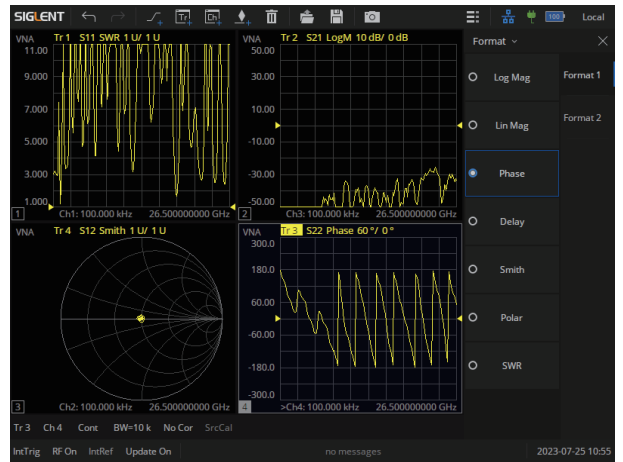

### Impedance conversion

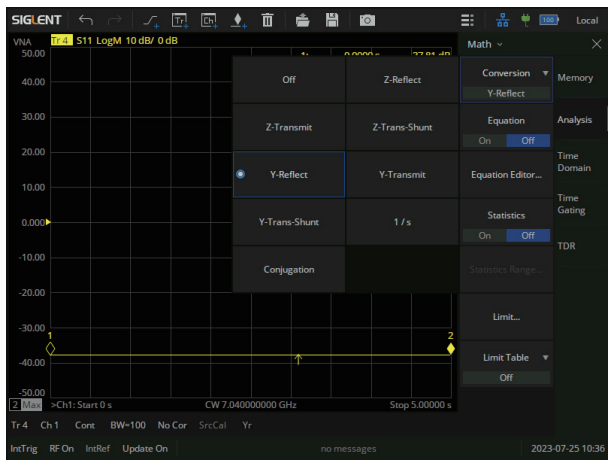

### Equation Editor

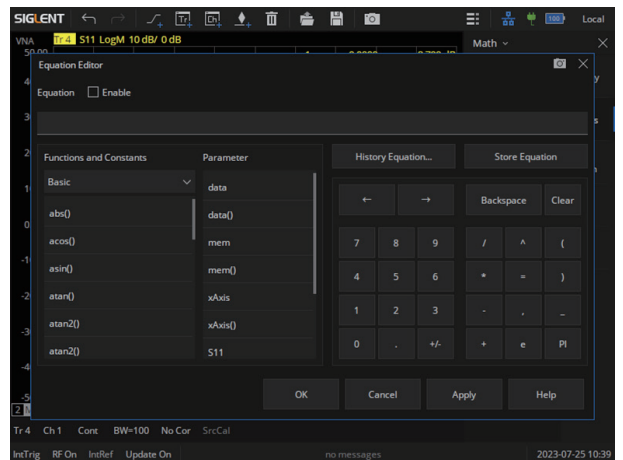

### Port Extensions

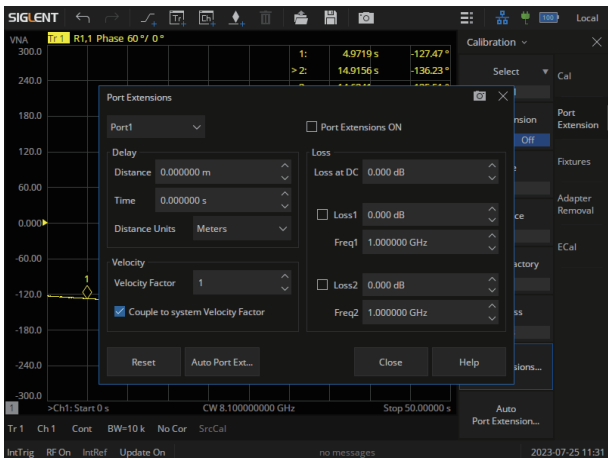

### Embedding and De-Embedding

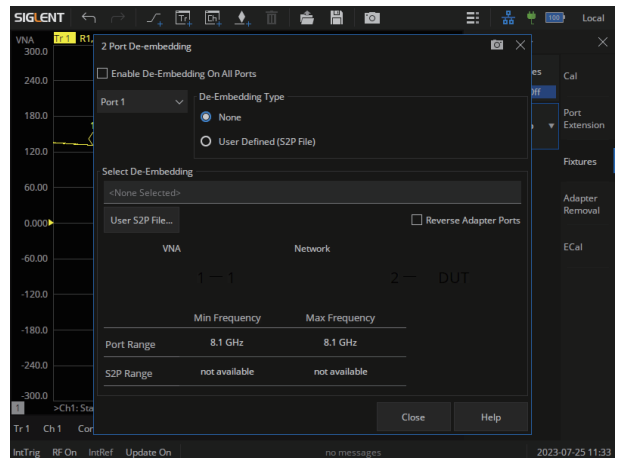

## CAT

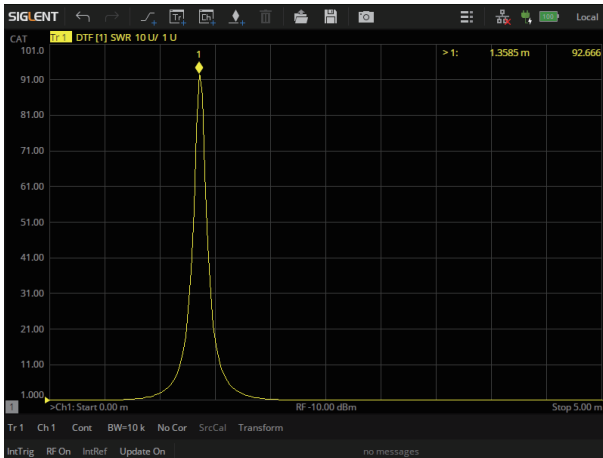

## Time-Domain analysis

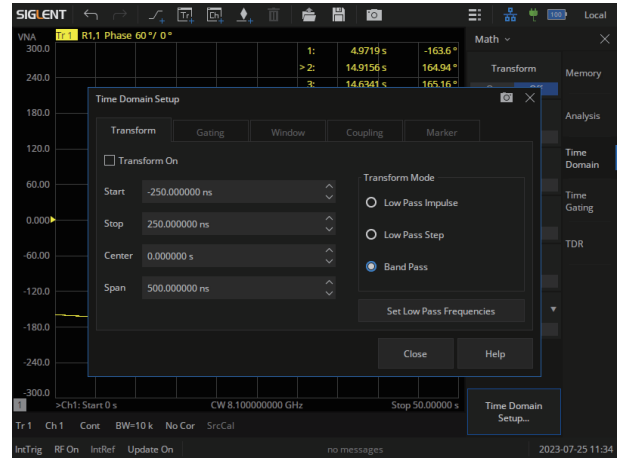

## Enhanced Time-Domain analysis (TDR)



## Spectrum analysis

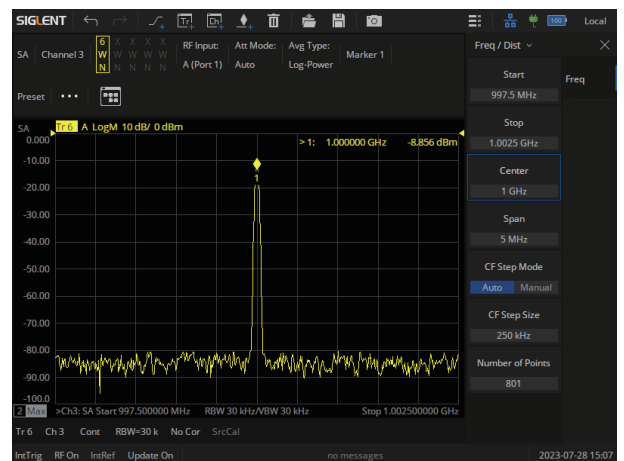

## Model and Main index

Model	SHN914A	SHN920A	SHN926A
Frequency range	30 kHz~14 GHz	30 kHz~20 GHz	30 kHz~26.5 GHz
Ports	2		
Frequency resolution	1 Hz		
Level resolution	0.05 dB		
Range of IFBW	10 Hz~3 MHz		
Setting range of output level	-45 dBm ~ +10 dBm		
Dynamic range	110 dB (Typ.)		
Types of calibration	Response calibration, Enhanced Response calibration, Full-one port calibration, Full-two port calibration, TRL calibration		
Types of measurement	Scattering-parameter measurement, differential-parameter measurement, receiver measurement, time-domain parameter analysis, limit test, ripple test, impedance conversion, fixture simulation, adapter removal/insertion, enhanced time-domain parameter analysis (TDR), spectrum analysis, frequency offset, scalar mixer measurement, pulse measurement		
Bias-Tees	Support		
Interface	LAN, USB Device, USB Host (USB-GPIB)		
Remote control	SCPI/ Labview/ IVI based on USB-TMC/ VXI-11/ Socket/ Telnet/ WebServer		
Display	8.4-inch touch screen		
GPS	Support		



## Ordering Information

Items	Description	Order number
Products	2 ports, 14 G Vector Network Analyzer	SHN914A
	2 ports, 20 G Vector Network Analyzer	SHN920A
	2 ports, 26.5 G Vector Network Analyzer	SHN926A
standard fittings	Quick Start, USB Type C Line, Rechargeable lithium battery, AC-DC adapter, Portable bag	
TDA Option	Time Domain Analysis	SHN900-TDA
TDR Option	Enhanced Time Domain Analysis	SHN900-TDR
SA Option	Spectrum analysis	SHN900-SA
	3.5 mm, Male, 50 $\Omega$ Calibration Kit, 0~4.5 GHz	F603ME
	3.5 mm, Female, 50 $\Omega$ Calibration Kit, 0~4.5 GHz	F603FE
	3.5 mm, Male, 50 $\Omega$ Calibration Kit, 0~9 GHz	F604MS
	3.5 mm, Female, 50 $\Omega$ Calibration Kit, 0~9 GHz	F604FS
	3.5 mm, Male and Female, 50 $\Omega$ Calibration Kit, 0~9 GHz	F604TS
	3.5 mm, Male and Female, 50 $\Omega$ Calibration Kit, 0~26.5 GHz	F606TS
	Electronic Calibration Kit	SEM5000A
	RF Test Demo Board	SNA-TB01
	Adjustable Differential TDR probe DC-18 GHz	ADP-18
	Adjustable Differential TDR probe DC-26.5 GHz	ADP-26
	Adjustable Differential TDR probe DC-18 GHz	ASP-18
	Adjustable Differential TDR probe DC-26.5 GHz	ASP-26
	SMA(M)-SMA(M) cable DC-18 GHz, 1000 mm	SMA-SMA-18L
	SMA(M)-SMA(M) cable DC-26.5 GHz, 1000 mm	SMA-SMA-26L
	SMA(F)-SMA(M) cable DC-26.5 GHz, 1000 mm	SMAF-SMA-26L
	NMD 3.5 female-NMD 3.5 Male DC-26.5 GHz, 635 mm	V26-N35MN35F-25IN
	NMD 3.5 female-APC 3.5 female DC-26.5 GHz, 635 mm	V26-N35FA35F-25IN
	USB-GPIB Adaptor	USB-GPIB
	GPS antenna, SMA(M), 1000 mm	ANT-GPS1



# SSM5000A

## Switch Matrix



### Features and Benefits

- Characteristic impedance: 50  $\Omega$
- Highest frequency: 9 GHz (or 26.5 GHz)
- Maximum number of input ports: 4
- Maximum number of output ports: 24
- RF connector: 3.5 mm female
- Maximum input power: 20 dBm
- Maximum input DC voltage: 35 V
- Interface: LAN, USB Device, Direct Control (in), Direct Control (out)
- Screen size: 2.4-inch



### Design features

#### • Network Analyzer Test Port Extension

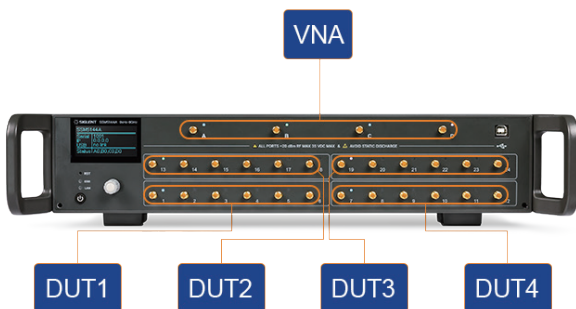

#### • Signal Generator and SA Test Port Extension

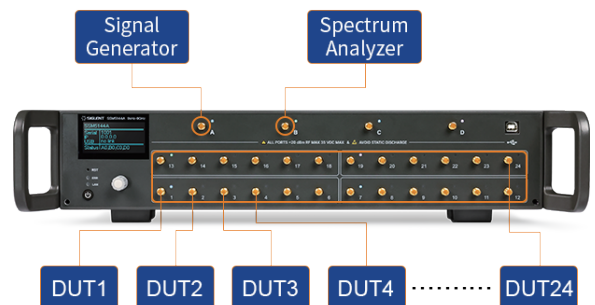



## Model and Main index

Model	SSM5122A	SSM5124A	SSM5142A	SSM5144A	SSM5321A	SSM5342A
Frequency range	9 kHz ~ 9 GHz	9 kHz ~ 9 GHz	9 kHz ~ 9 GHz	9 kHz ~ 9 GHz	100 kHz ~ 26.5 GHz	100 kHz ~ 26.5 GHz
Input	2	2	4	4	2	4
Output	12	24	12	24	6	12
RF connector	3.5 mm Female					
Maximum input power	20 dBm					
Maximum input DC voltage	35 V					
Screen size	2.4-inch					
Size	W×H×D = 88.5×425×417.6 mm					



## Ordering Information

Items	Description	Frequency range	Order number
Products	2 input ports, 12 output ports	9 kHz ~ 9 GHz	SSM5122A
	2 input ports, 24 output ports	9 kHz ~ 9 GHz	SSM5124A
	4 input ports, 12 output ports	9 kHz ~ 9 GHz	SSM5142A
	4 input ports, 24 output ports	9 kHz ~ 9 GHz	SSM5144A
	2 input ports, 6 output ports	100 kHz ~ 26.5 GHz	SSM5321A
	4 input ports, 12 output ports	100 kHz ~ 26.5 GHz	SSM5342A
Standard Accessories	One Quick-start, One Power-cable, One USB-cable, One certificate of qualification	-	-



# SSU5000A

## Mechanical Switch



### Features and Benefits

- Maximum frequency: 18 GHz/ 26.5 GHz/ 50 GHz
- 1 to 4 SPDT switches or 1 to 2 SP6T switch configurations
- SCPI Controllable via VISA and EasySSU software
- USB Connectivity
- Size: WxHxD=153x62.4x137.5 mm
- RF connector: SMA female or 2.4 mm female



### Model and Main index

Model	SSU5181A/SSU5182A SSU5183A/SSU5184A	SSU5261A/SSU5262A SSU5263A/SSU5264A	SSU5265A SSU5266A	SSU5501A/SSU5502A SSU5503A/SSU5504A
Frequency range	DC ~ 18 GHz	DC ~ 26.5 GHz	DC ~ 26.5 GHz	DC ~ 50 GHz
Number of Switches	1/2/3/4	1/2/3/4	1/2	1/2/3/4
Switch Type	SPDT	SPDT	SP6T	SPDT
RF connector	SMA female			2.4 mm female
Driving voltage	12 V			
Maximum driving current	1.25 A			
Size	W×H×D = 153×62.4×137.5 mm			
Weight	885 g			



## Ordering Information

Model	Product Description
SSU5181A	DC ~ 18 GHz, including one SPDT mechanical switch
SSU5182A	DC ~ 18 GHz, including two SPDT mechanical switches
SSU5183A	DC ~ 18 GHz, including three SPDT mechanical switches
SSU5184A	DC ~ 18 GHz, including four SPDT mechanical switches
SSU5261A	DC ~ 26.5 GHz, including one SPDT mechanical switch
SSU5262A	DC ~ 26.5 GHz, including two SPDT mechanical switches
SSU5263A	DC ~ 26.5 GHz, including three SPDT mechanical switches
SSU5264A	DC ~ 26.5 GHz, including four SPDT mechanical switches
SSU5265A	DC ~ 26.5 GHz, including one SP6T mechanical switch
SSU5266A	DC ~ 26.5 GHz, including two SP6T mechanical switches
SSU5501A	DC ~ 50 GHz, including one SPDT mechanical switch
SSU5502A	DC ~ 50 GHz, including two SPDT mechanical switches
SSU5503A	DC ~ 50 GHz, including three SPDT mechanical switches
SSU5504A	DC ~ 50 GHz, including four SPDT mechanical switches
Standard Configurations	Quantity
USB-cable	1
Quick-start	1
AC-DC adapter	1
Power cord	1
Certificate of qualification	1



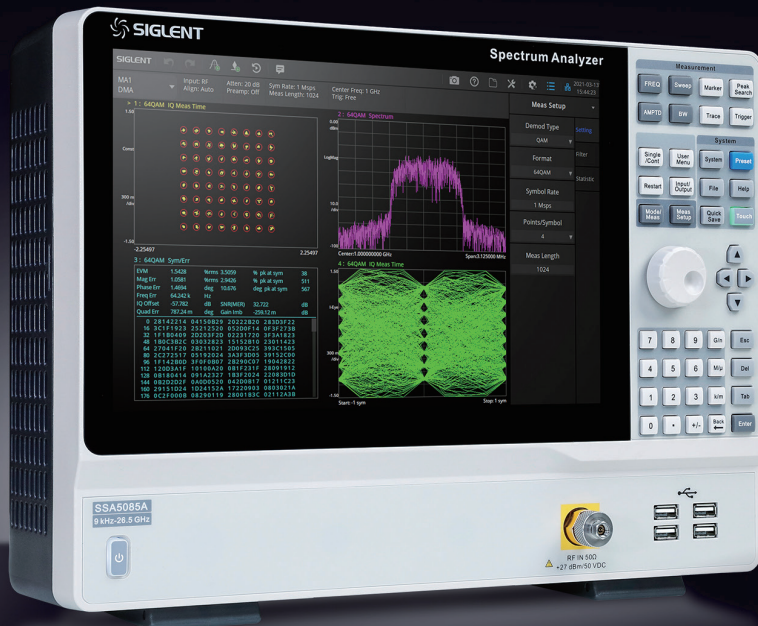

# SSA5000A

## Spectrum Analyzer

### Features and Benefits

- Spectrum Analyzer Frequency Range from 9 kHz up to 13.6 GHz/26.5 GHz
- -165 dBm/Hz Displayed Average Noise Level (Typ.)
- -105 dBc/Hz@1 GHz, 10 kHz offset SSB Phase Noise (Typ.)
- 25 MHz/40 MHz Analysis Bandwidth
- 100% POI 7.20  $\mu$ s, Dynamic Range 60 dB, Multi-view for Density, Spectrogram and PVT
- Channel power, ACPR, OBW, Harmonic, TOI measurement etc.
- Analog Modulation Analysis and Vector Digital Modulation Analysis
- 12.1 inch Multi-Touch Screen, HDMI output
- Web Browser Remote Control on PC and Mobile Terminals and File Operation

### Design features

#### • Real Time Analysis Mode

Multi-view and dimensions to monitor complex signals

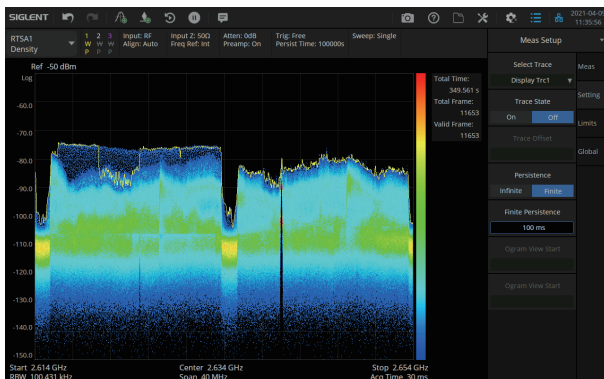

#### • Modulation Analysis Mode

AM/FM/PM analog modulation , and ASK/FSK/PSK/MSK/QAM vector modulation a nalysis

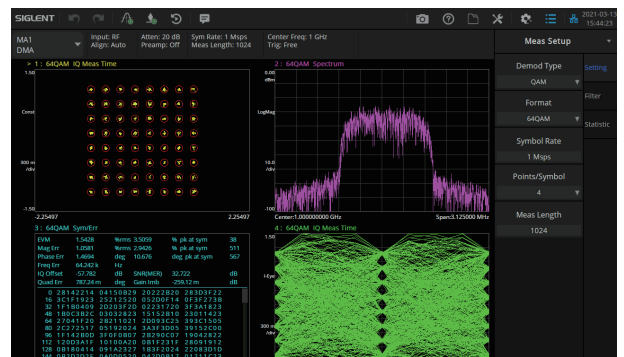

# SSA5000A Spectrum Analyzer

## Bluetooth Signal Modulation Analysis

Provide transmitter tests of Low Energy, Basic Rate and Enhanced Data Rate Bluetooth standard

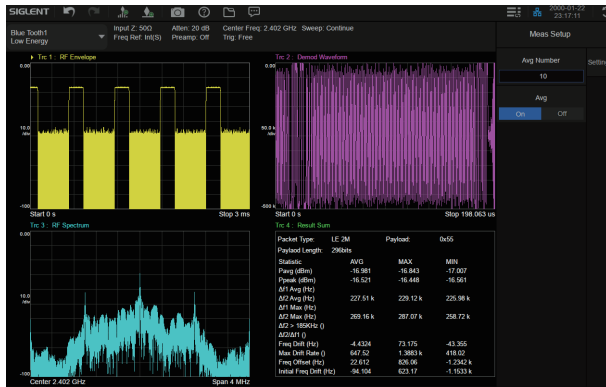

## Noise Figure Mode

The noise figure of systems such as amplifiers and frequency converters

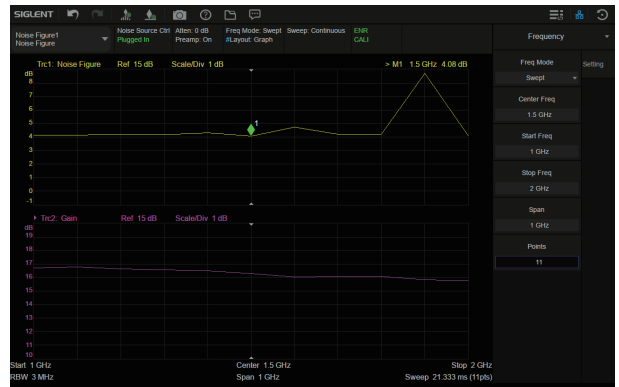

## Phase Noise Analysis

One-sided band phase noise test analysis, jitter analysis, etc

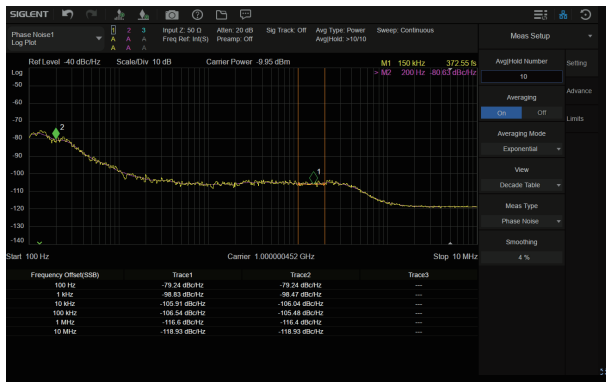

## Pulse Measurement Analysis

Measure the time and frequency parameters of the RF pulses



## Model and Main index

Model	SSA5083A	SSA5085A
Frequency Range	9 kHz~13.6 GHz	9 kHz~26.5 GHz
Displayed Average Noise Level	-165 dBm/Hz	
SSB Phase Noise	<-105 dBc/Hz	
Analysis Bandwidth	25 MHz, 40 MHz (opt.)	



## Ordering Information

Product	Description	Order Number
Product Code	Spectrum Analyzer, 9 kHz ~ 13.6 GHz	SSA5083A
	Spectrum Analyzer, 9 kHz ~ 26.5 GHz	SSA5085A
Standard	Quick Start, USB Cable, Power Cord, Wireless Mouse, 2.92F-2.92F-40A	
Options	SSA5083A upgrade to SSA5085A	SSA5000-F5
	Pre-Amplifier, 9 kHz ~ 13.6 GHz	SSA5000-P3
	Pre-Amplifier, 9 kHz ~ 26.5 GHz	SSA5000-P5
	40 MHz analysis bandwidth	SSA5000-B40
	Real-Time Spectrum Analysis	SSA5000-RTA1
	Advanced Measurement Kit	SSA5000-AMK
	IQ Data Acquisition	SSA5000-IQA
	Pulse Measurement	SSA5000-PU
	Phase Noise Measurement	SSA5000-PN
	Noise Figure Measurement	SSA5000-NF
	Analog Modulation Analysis	SSA5000-AMA
	Digital Modulation Analysis	SSA5000-DMA
	Bluetooth Analysis	SSA5000-BT
	EMI Measurement	SSA5000-EMI
	IF Output	SSA5000-IFO
Accessories	OCXO Precise Reference source, Factory installed	10M_OCXO_L
	2.92mm(F)-2.92mm(F) adaptor, DC ~ 40 GHz	2.92F-2.92F-40A
	N(M)-N(M) cable, DC ~ 18 GHz, 1000 mm	N-N-18L
	N(M)-SMA(M) cable, 18 GHz, 1000 mm	N-SMA-18L
	SMA(M)-SMA(M) cable, 18 GHz, 1000 mm	SMA-SMA-18L
	SMA(M)-SMA(M) cable, 26.5 GHz, 1000 mm	SMA-SMA-26L
	SMA(F)-SMA(M) cable, 26.5 GHz, 1000 mm	SMAF-SMA-26L
	USB-GPIB Adaptor	USB-GPIB
300 kHz~3 GHz Near Field Probe Kit: 3 H-probes (20/10/5 mm), 1 E-probe (5 mm)	SRF5030T	

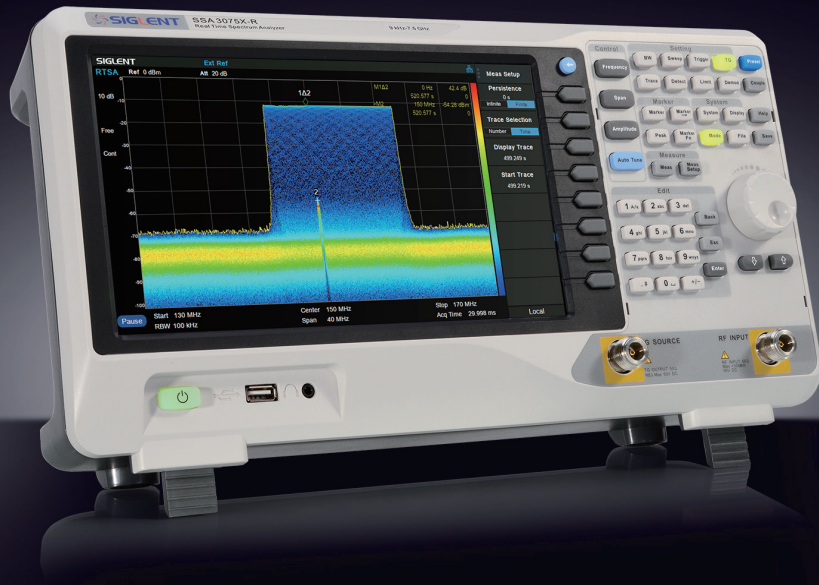

# SSA3000X-R

## Real-Time Spectrum Analyzer



### Features and Benefits

- Spectrum Analyzer Frequency Range from 9 kHz up to 7.5 GHz
- Vector Network Analyzer Frequency Range from 100 kHz up to 7.5 GHz
- -165 dBm/Hz Displayed Average Noise Level (Typ.)
- -98 dBc/Hz.@10 kHz Offset Phase Noise (1 GHz, Typ.)
- Level Measurement Uncertainty < 0.7 dB (Typ.)
- 1 Hz Minimum Resolution Bandwidth (RBW)
- Preamplifier and Tracking Generator Standard
- Up to 40 MHz Real Time Analysis Bandwidth (Opt.)
- 100% POI 7.20  $\mu$ s, Dynamic Range 60 dB, Multi-view for Density, Spectrogram, PVT and 3D
- Distance To Fault
- Advanced Measurement Kit (Opt.)
- Modulation Analysis Mode (Opt.)
- EMI Measurement Mode (Opt.)
- 10.1 inch Multi-Touch Screen , Mouse and Keyboard supported
- Web Browser Remote Control on PC and Mobile Terminals and File Operation

**Design features**

• 10.1 Inch Display with Multi-Touch Screen

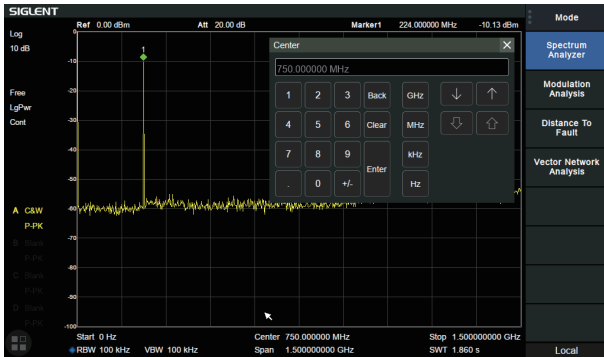

• Phase noise <math>< -98 \text{ dBc/Hz}@1 \text{ GHz}</math>

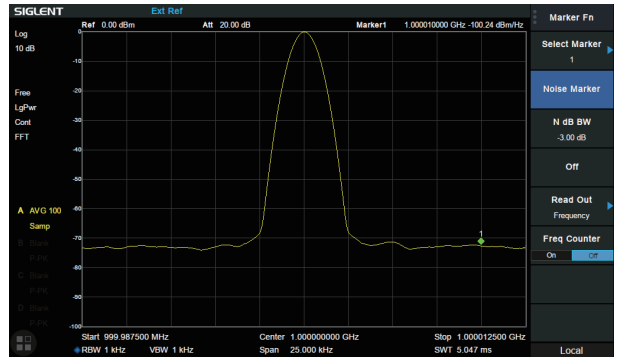

• Minimum 1 Hz Resolution Bandwidth (RBW)

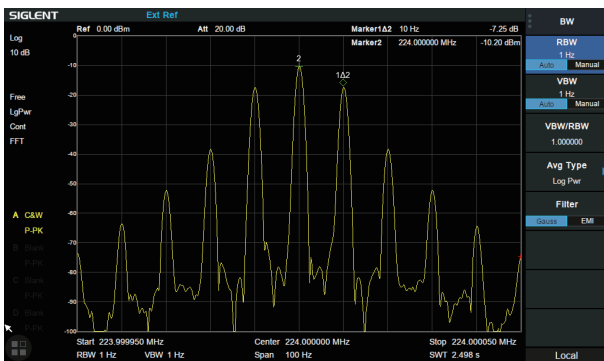

• ACPR in Advanced Measurement Kit

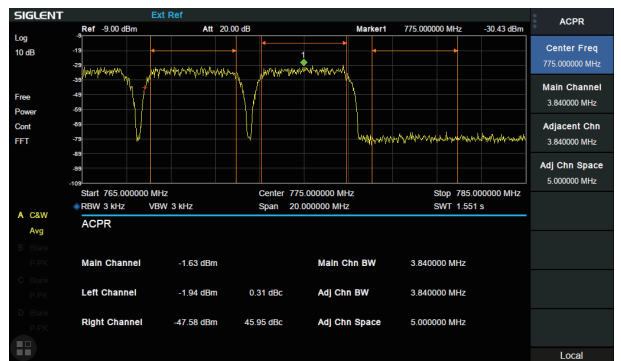

• -165 dBm/Hz Displayed Average Noise Level

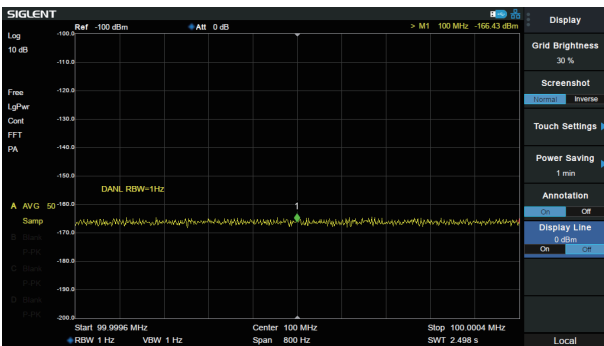

• Monitor in Advanced Measurement Kit

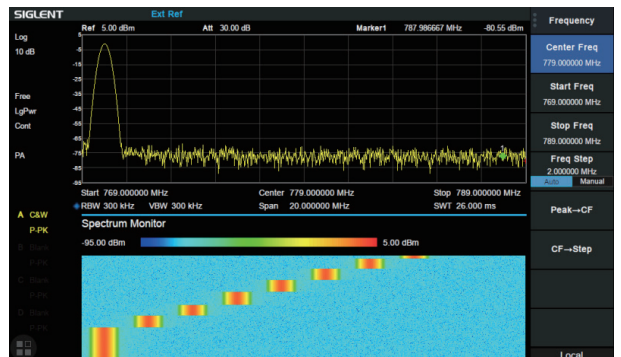

# SSA3000X-R Real-Time Spectrum Analyzer

## • Modulation Analysis Mode

AM/FM, ASK/FSK/PSK/MSK/QAM Vector Signal Modulation Analysis and EVM evaluation. The analysis BW is same with real-time BW in RTSA mode

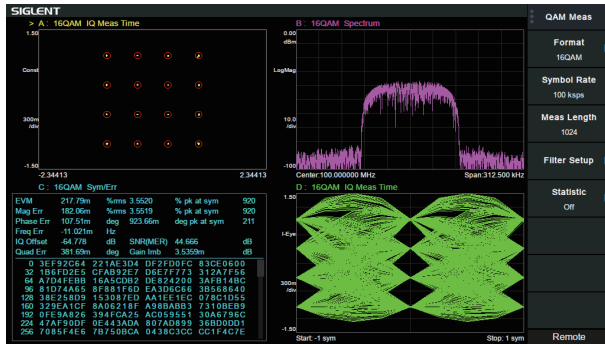

## • Vector Network Analyzer Mode

100 kHz~7.5 GHz Vector S11 and S21 measurement, Multi Formats Overlay Display

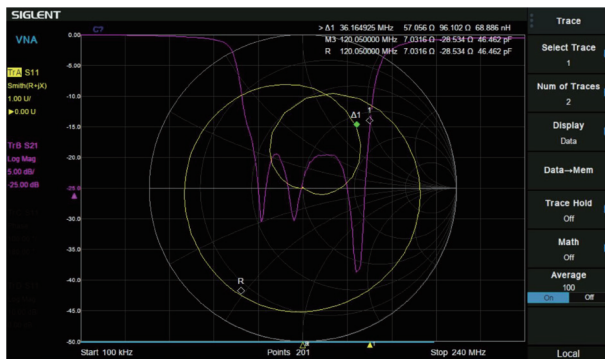

## • Real Time Analysis Mode

Density, 3D, Spectrogram, PvT, Multi-view and dimensions to monitor complex signals

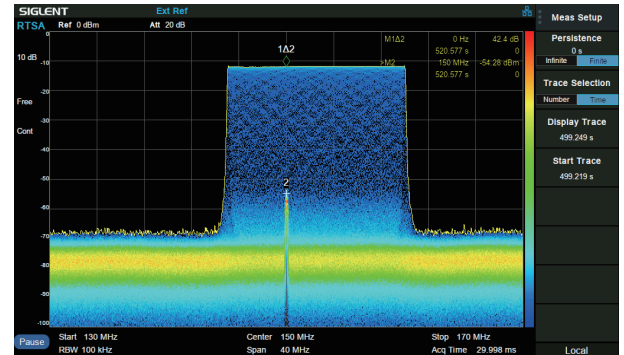

## • EMI Measurement Mode

EMI Measurement with CISPR 16-1-1 EMI filter, Quasi-peak Detector, and pre-stored standards



## Model and Main index

Model	SSA3032X-R	SSA3050X-R	SSA3075X-R
Frequency Range	9 kHz~3.2 GHz	9 kHz~5.0 GHz	9 kHz~7.5 GHz
Resolution Bandwidth	1 Hz~3 MHz	1 Hz~3 MHz	1 Hz~3 MHz
Displayed Average Noise Level	-165 dBm/Hz	-165 dBm/Hz	-165 dBm/Hz
SSB Phase Noise	<-98 dBc/Hz	<-98 dBc/Hz	<-98 dBc/Hz
Third-order intercept(TOI)	+14 dbm	+14 dbm	+14 dbm
Total Amplitude Accuracy	< 0.7 dB	< 0.7 dB	< 0.7 dB
Tracking Generator	100 kHz~3.2 GHz	100 kHz~5.0 GHz	100 kHz~7.5 GHz
Real Time Band Width	25 MHz, 40 MHz (Option)		
RTSA SFDR	60 dB		
100% POI	7.20 μs		
RTSA Measurement	Density, Spectrogram, 3D, PvT		
VNA measurement	Vector S11, Vector S21		
VNA Dynamic Range	90 dB		
Distance to Fault	Timing Domain Analysis Locator		
Touch Screen	Multi Touch, Mouse and Keyboard supported		
Advanced Measurement	CHP, ACPR, OBW, CNR, Harmonic, TOI, Monitor		
Modulation Analysis	AM, FM, ASK, FSK, MSK, PSK, QAM		
EMI Measurement	EMI Filter and Quasi-Peak Detector, Log Scale and Limit Line		
Communication Interface	LAN, USB Device, USB Host (USB-GPIB)		
Remote Control Capability	SCPI/Labview/IVI based on USB-TMC/VXI-11/Socket/Telnet		
Remote Controller	NI-MAX, Web Browser, Easy Spectrum software, File Explorer		



## Ordering Information

Product	Description	Order Number
Product Code	Real Time Spectrum Analyzer, 9 kHz~3.2 GHz, Preamp and TG standard, VNA standard	SSA3032X-R
	Real Time Spectrum Analyzer, 9 kHz~5.0 GHz, Preamp and TG standard, VNA standard	SSA3050X-R
	Real Time Spectrum Analyzer, 9 kHz~7.5 GHz, Preamp and TG standard, VNA standard	SSA3075X-R
Standard Accessories	Quick Start, USB Cable, Power Cord	
Common Options and Accessories	Advanced Measurement Kit	SSA3000XR-AMK
	40 MHz Analysis BandWidth	SSA3000XR-RT40
	Utility Kit: N(M)-SMA(M) cable(6 GHz), N(M)-N(M) cable(6 GHz), N(M)-BNC(F) adaptor x2, N(M)-SMA(F) adaptor x2, 10 dB 1W attenuator	UKitSSA3X
	N(M)-BNC(M) cable, 70 cm, 2 GHz	N-BNC-2L
	N(M)-SMA(M) cable, 70 cm, 6 GHz	N-SMA-6L
	N(M)-N(M) cable, 70 cm, 6 GHz	N-N-6L
	N(M)-SMA(M) cable, 100 cm, 18 GHz	N-SMA-18L
	N(M)-N(M) cable, 100 cm, 18 GHz	N-N-18L
	SMA(M)-SMA(M) cable, 100 cm, 18 GHz	SMA-SMA-18L
	USB-GPIB Adaptor	USB-GPIB
	Soft carrying bag	BAG-S2
	6U Rack Mount Kit	SSA-RMK
VNA Options	N type Economic Calibration Kit, DC~4.5 GHz, 50 Ω	F503ME
	N type Economic Calibration Kit, DC~4.5 GHz, 50 Ω	F503FE
	3.5 mm type Economic Calibration Kit, DC~4.5 GHz, 50 Ω	F603ME
	3.5 mm type Economic Calibration Kit, DC~4.5 GHz, 50 Ω	F603FE
	N type Standard Calibration Kit, DC~9 GHz, 50 Ω	F504MS
	N type Standard Calibration Kit, DC~9 GHz, 50 Ω	F504FS
	3.5 mm type Standard Calibration Kit, DC~9 GHz, 50 Ω	F604MS
	3.5 mm type Standard Calibration Kit, DC~9 GHz, 50 Ω	F604FS
EMI Measurement Options	EMI Measurement Mode	SSA3000XR-EMI
	300 kHz~3 GHz Near Field Probe Kit: 3 H-probes (20/10/5 mm), 1 E-probe (5 mm)	SRF5030T
Modulation Analysis Options	Analog Modulation Analysis: AM, FM	SSA3000XR-AMA
	Digital Modulation Analysis: ASK, FSK, MSK, PSK, QAM	SSA3000XR-WDMA

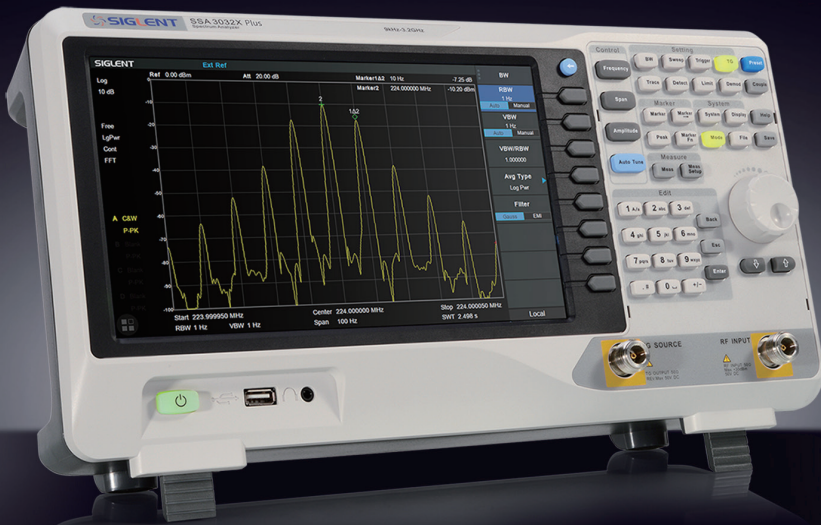

# SSA3000X Plus

## Spectrum Analyzer



### Features and Benefits

- Frequency Range from 9 kHz up to 7.5 GHz
- -165 dBm/Hz Displayed Average Noise Level (Typ.)
- -98 dBc/Hz.@10 kHz Offset Phase Noise (1 GHz, Typ.)
- Level Measurement Uncertainty < 0.7 dB (Typ.)
- 1 Hz Minimum Resolution Bandwidth (RBW)
- Preamplifier Standard
- Tracking Generator included at no charge
- Vector Signal Modulation Analysis (Opt.)
- EMI Filter and Quasi-Peak Detector (Opt.)
- Advanced Measurement Kit (Opt.)
- 10.1 Inch Multi-Touch Screen , Mouse and Keyboard supported
- Web Browser Remote Control on PC and Mobile Terminals and File Operation



### Design features

#### • 10.1 Inch (1024x600) Touch Screen

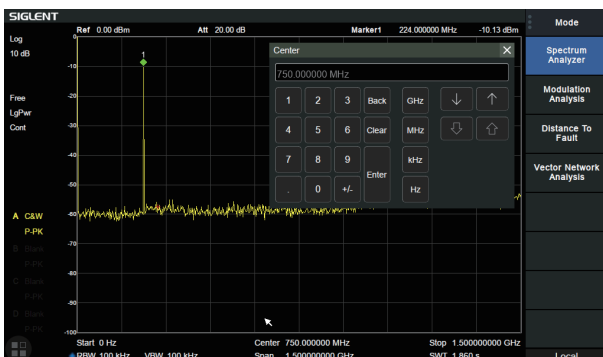

#### • Minimum 1 Hz Resolution Bandwidth (RBW)

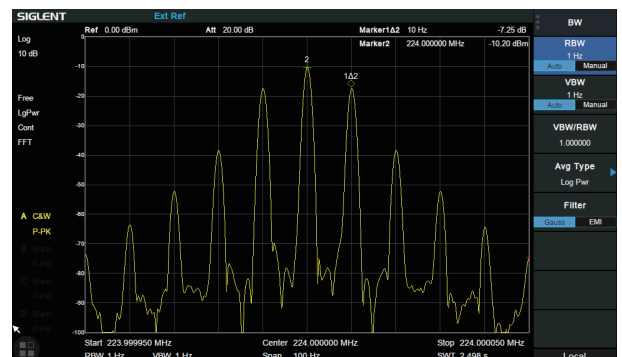



## • -165 dBm/Hz Displayed Average Noise Level

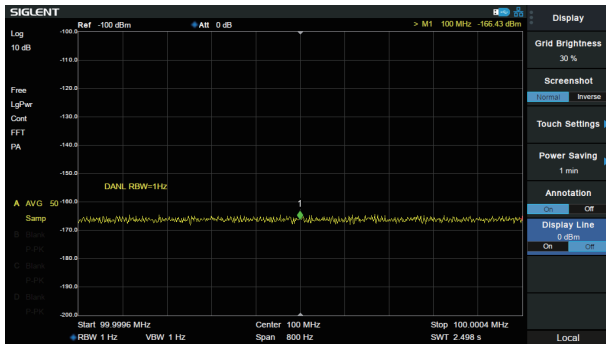

## • Phase noise <-98 dBc/Hz@1 GHz

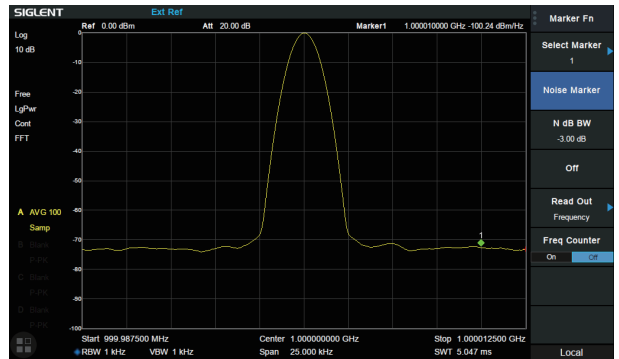

## • Advanced Measurement Kit

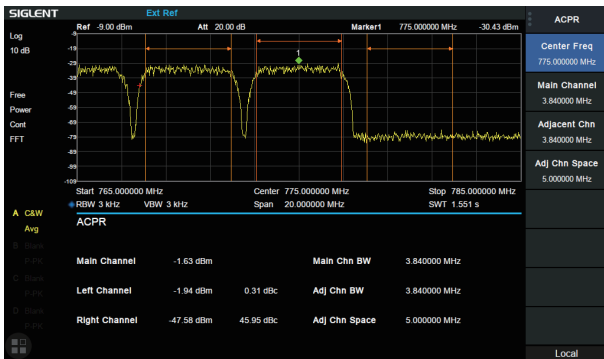

## • Spectrum Monitor in Advanced Measurement Kit

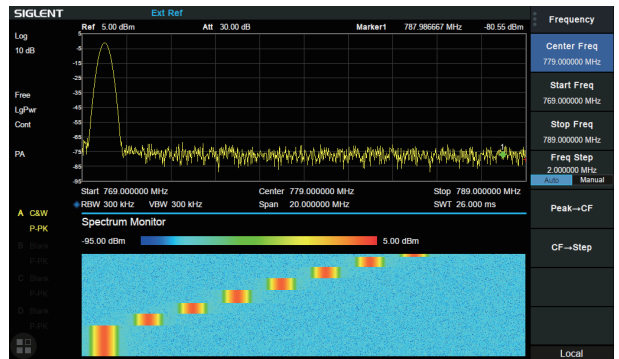

## • Modulation Analysis Mode

AM/FM, ASK/FSK/PSK/MSK/QAM Vector Signal Modulation Analysis, EVM evaluation

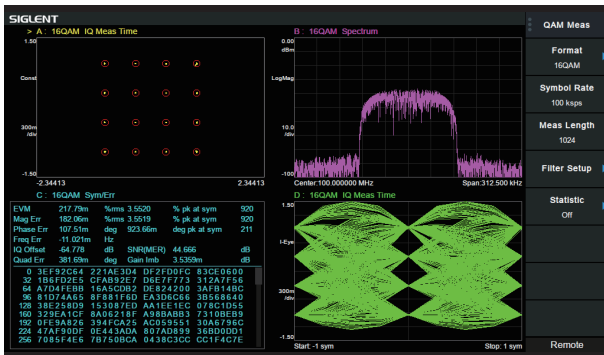

## • EMI Measurement Mode

EMI Measurement with CISPR 16-1-1 EMI filter, Quasi-peak Detector, and pre-stored standards





## Model and Main Index

Model	SSA3015X Plus	SSA3021X Plus	SSA3032X Plus	SSA3075X Plus
Frequency Range	9 kHz~1.5 GHz	9 kHz~2.1 GHz	9 kHz~3.2 GHz	9 kHz~7.5 GHz
Resolution Bandwidth	1 Hz~1 MHz	1 Hz~1 MHz	1 Hz~1 MHz	1 Hz~3 MHz
Displayed Average Noise Level	-156 dBm/Hz	-161 dBm/Hz	-161 dBm/Hz	-165 dBm/Hz
SSB Phase Noise	< -99 dBc/Hz	< -98 dBc/Hz	< -98 dBc/Hz	< -98 dBc/Hz
Third-order intercept	+10 dBm	+10 dBm	+10 dBm	+14 dBm
Total Amplitude Accuracy	< 1.2 dB	< 0.7 dB	< 0.7 dB	< 0.7 dB
Tracking Generator	100 kHz~1.5 GHz	100 kHz~2.1 GHz	100 kHz~3.2 GHz	100 kHz~7.5 GHz
Touch Screen	Multi Touch, Mouse and Keyboard supported			
Advanced Measurement	CHP, ACPR, OBW, CNR, Harmonic, TOI, Monitor			
Reflection Measurement	VSWR measurement using Reflection Bridge			
EMI Test	EMI Filter and Quasi-Peak Detector, Log Scale and Limit Line			
Modulation Analysis	AM, FM; ASK, FSK, MSK, PSK, QAM			
Communication Interface	LAN, USB Device, USB Host (USB-GPIB)			
Remote Control Capability	SCPI/Labview/IVI based on USB-TMC/VXI-11/Socket/Telnet			
Remote Controller	NI-MAX, Web Browser, Easy Spectrum software, File Explorer			



## Ordering Information

Product	Description	Order Number
Product Code	Spectrum Analyzer, 9 kHz ~ 1.5 GHz	SSA3015X Plus
	Spectrum Analyzer, 9 kHz ~ 2.1 GHz	SSA3021X Plus
	Spectrum Analyzer, 9 kHz ~ 3.2 GHz	SSA3032X Plus
	Spectrum Analyzer, 9 kHz ~ 7.5 GHz	SSA3075X Plus
Standard Accessories	Quick Start, USB Cable, Power Cord	
Common Options and Accessories	Tracking Generator	SSA3000XP-TG
	Advanced Measurement Kit	SSA3000XP-AMK
	Utility Kit: N (M)-SMA (M) cable (6 GHz), N (M)-N (M) cable (6 GHz), N (M)-BNC (F) adaptor x2, N (M)-SMA (F) adaptor x2, 10 dB 1W attenuator	UKitSSA3X
	N (M)-BNC (M) cable, 70 cm, 2 GHz	N-BNC-2L
	N (M)-SMA (M) cable, 70 cm, 6 GHz	N-SMA-6L
	N (M)-N (M) cable, 70 cm, 6 GHz	N-N-6L
	N (M)-SMA (M) cable, 100 cm, 18 GHz	N-SMA-18L
	N (M)-N (M) cable, 100 cm, 18 GHz	N-N-18L
	SMA (M)-SMA (M) cable, 100 cm, 18 GHz	SMA-SMA-18L
	USB-GPIB Adaptor	USB-GPIB
	Soft carrying bag	BAG-S2
	6U Rack Mount Kit	SSA-RMK
Reflection Measurement Options	Tracking Generator	SSA3000XP-TG
	Reflection Measurement	SSA3000-RefI
	Reflection Bridge Kit: Reflection Bridge (1 MHz~2.5 GHz), N(M)-N(M) adaptors x2	RB3X25
	50 Ω, N type Male, 4.5 GHz Economic Calibration Kit: Open(M), Short(M), Match(M), Through Adapter(F-F)	F503ME
EMI test Options	EMI Measurement Mode	SSA3000XP-EMI
	300 kHz~3 GHz Near Field Probe Kit: 3 H-probes (20/10/5 mm), 1 E-probe (5 mm)	SRF5030T
Modulation Analysis Options	Digital Modulation: ASK, FSK, MSK, PSK, QAM	SSA3000XP-DMA
	Analog Modulation: AM, FM	SSA3000XP-AMA



# SSA3000X

## Spectrum Analyzer



### Features and Benefits

- All-Digital IF Technology
- Frequency Range from 9 kHz up to 3.2 GHz
- -161 dBm/Hz Displayed Average Noise Level (Typ.)
- -98 dBc/Hz @10 kHz Offset Phase Noise (1 GHz, Typ.)
- Total Amplitude Accuracy < 0.7 dB
- 1 Hz Minimum Resolution Bandwidth (RBW)
- Preamplifier Standard
- Up to 3.2 GHz Tracking Generator Kit
- Reflection Measurement Kit (Opt.)
- Advanced Measurement Kit (Opt.)
- EMI Pre-compliance Measurements Kit (Opt.)
- 10.1 Inch WVGA (1024x600) Display



### Design features

- Support four traces and cursors independently

- 1 Hz Minimum Resolution Bandwidth (RBW)

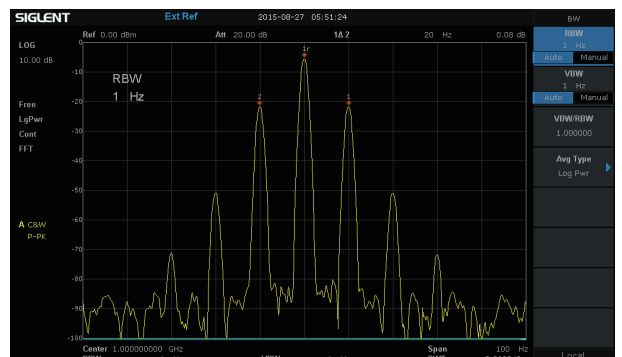

- 151 dBm Displayed Average Noise Level (RBW=10 Hz)

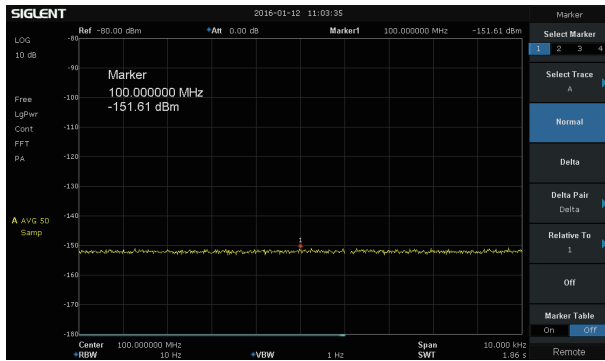

- Phase noise -98 dBc/Hz@1 GHz, offset 10 kHz

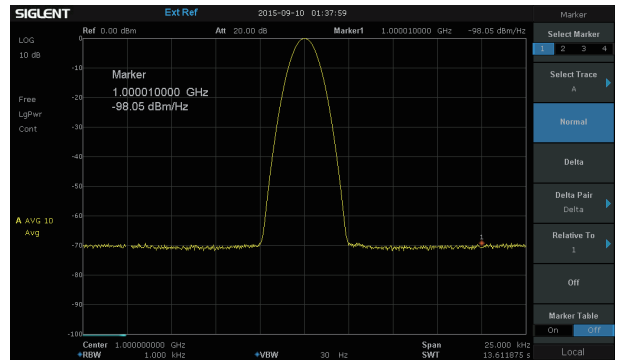

- Demodulation at the zero span

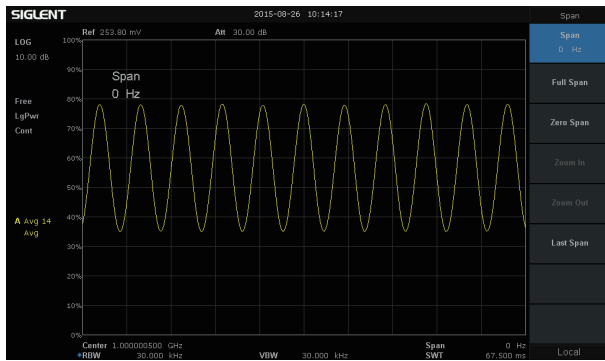

- Advanced power measurement, calculate the ACPR parameters

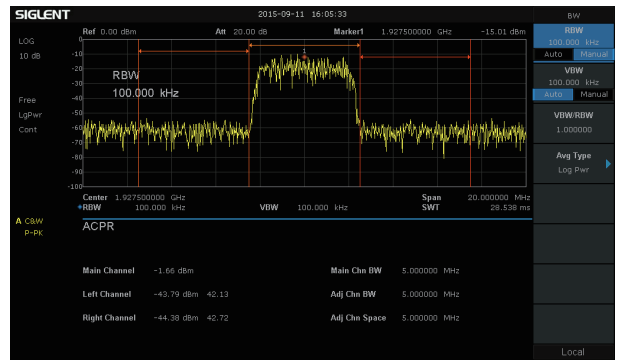

- Reflection measurement, acquire characteristic curve of the Return Loss

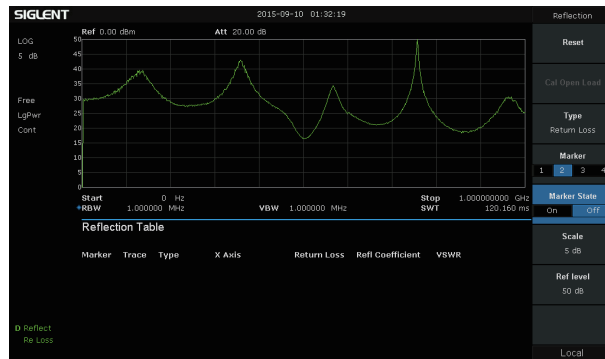

- EMI filter, Quasi-Peak detector following CISPR 16

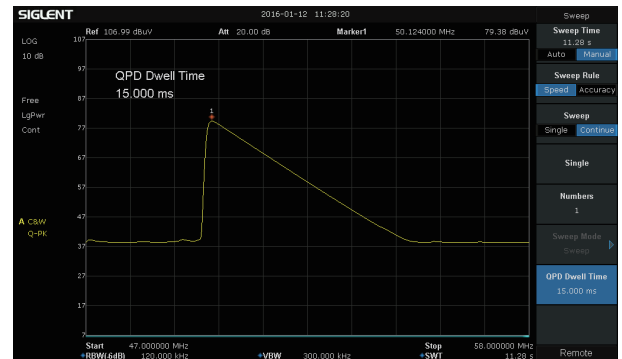

## Model and Main index

Model	SSA3021X	SSA3032X
Frequency Range	9 kHz~2.1 GHz	9 kHz~3.2 GHz
Resolution Bandwidth	1 Hz~1 MHz, in 1-3-10 sequence	1 Hz~1 MHz, in 1-3-10 sequence
Displayed Average Noise Level	-161 dBm/Hz, Normalize to 1 Hz (typ.)	-161 dBm/Hz, Normalize to 1 Hz (typ.)
Phase Noise	<-98 dBc/Hz@1 GHz, 10 kHz offset	<-98 dBc/Hz@1 GHz, 10 kHz offset
Amplitude Precision	< 0.7 dB	< 0.7 dB



## Ordering Information

Product Description	SSA3000X Spectrum Analyzer	Order Number
Product code	Spectrum Analyzer, 9 kHz~3.2 GHz	SSA3032X
	Spectrum Analyzer, 9 kHz~2.1 GHz	SSA3021X
Standard configurations	A Quick Start, A USB Cable, A Power Cord, A Calibration Certificate	QG-SSA3000X
Utility Options	Tracking Generator Kit	TG-SSA3000X
	Advanced Measurement Kit	AMK-SSA3000X
	Utility Kit: N(M)-SMA(M) cable N(M)-N(M) cable N(M)-BNC(F) adaptor(2 pcs) N(M)-SMA(F) adaptor(2 pcs) 10 dB attenuator	UKitSSA3X
	N(M)-SMA(M) cable	N-SMA-6L
	N(M)-N(M) cable	N-N-6L
	N(M)-BNC(M) cable	N-BNC-2L
	Soft carrying bag	BAG-SCC
	Rack Mount Kit	SSA-RMK
	EMI Options	EMI Measurement Kit: EMI Filter and Quasi Peak Detector, EMI test option in EasySpectrum Software
Near Field Probe:H field probe sets(25 mm, 10 mm, 5 mm, 2mm), 30 MHz~3.0 GHz		SRF5030
Near Field Probe:H field probe sets(20 mm, 10 mm, 5 mm) , E field probe (5 mm), 300 kHz~3.0 GHz		SRF5030T
Reflect Measurement Options	Tracking Generator Kit	TG-SSA3000X
	Reflect Measurement Kit	Refl-SSA3000X
	VSWR Bridge Kit: including Refl-SSA3000X VSWR Bridge(1 MHz~2 GHz) N(M)-N(M) adaptor(2 pcs)	RBSSA3X20



# SHA850A

## Portable Spectrum Analyzer



### Features and Benefits

- Spectrum Analyzer Frequency Range from 9 kHz up to 7.5 GHz, -165 dBm/Hz Displayed Average Noise Level (Typ.), -104 dBc/Hz.@10 kHz Offset Phase Noise (1 GHz, Typ.), 1 Hz up to 10 MHz Minimum Resolution Bandwidth (RBW), Preamplifier and independent signal source up to 7.5 GHz, GPS positioning and logging
- Cable and Antenna Test Frequency Range from 100 kHz up to 7.5 GHz, Distance To Fault and Time Domain Analysis
- Vector Network Analyzer, Bias out up to 32VDC
- Typical working time 4 hours, 3.2 kg net weight, 8.4 Inch Multi-Touch Screen , Mouse and Keyboard supported



### Design features

#### • Spectrum Analyzer 8.4 inch multi-touch screen and full keyboard control

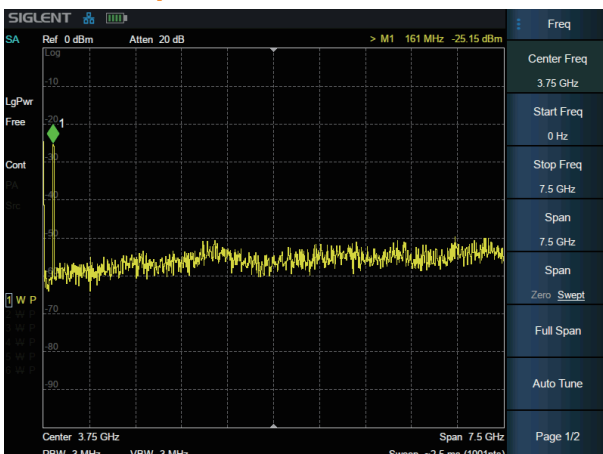

#### • Channel Power and ACPR measurement

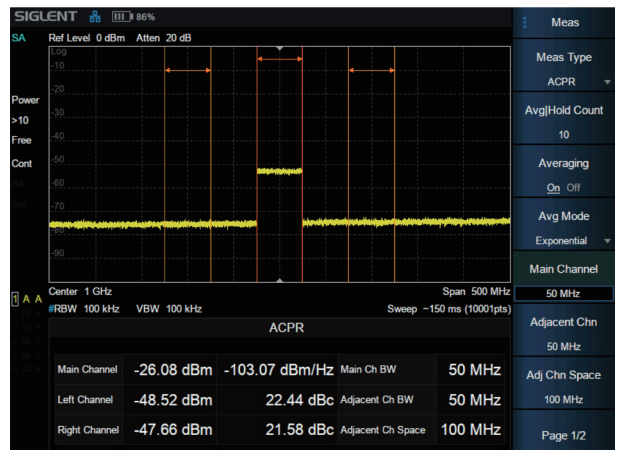

● **GPS Location and trace log recorder, sync 10MHz reference clock**

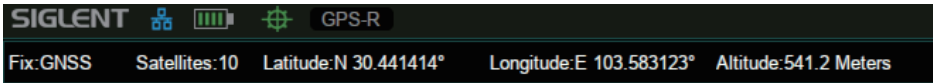

● **Interference analysis with directional antenna**



● **Vector Network Analyzer**

100 kHz-7.5 GHz Vector S11 and S21 measurement, Multi Formats Overlay Display

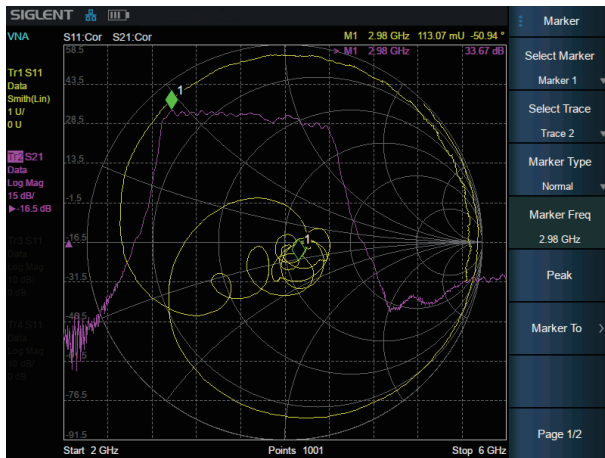

● **Modulation Analysis**

AM/FM/PM analog modulation, and ASK/FSK/PSK/MSK/QAM digital modulation analysis

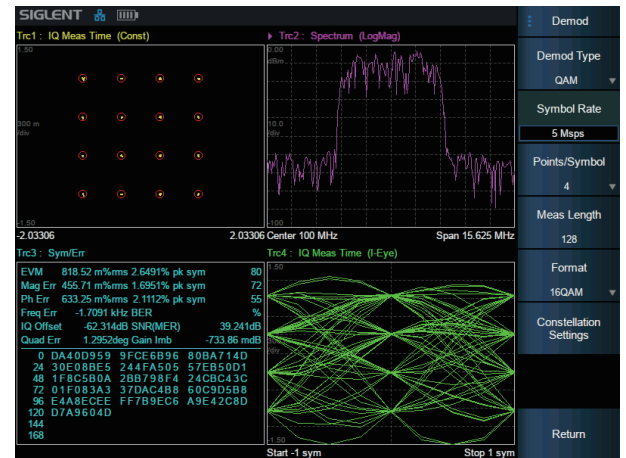

● **Cable and Antenna Test**

Cable and Antenna Test based on Timing Domain Analysis

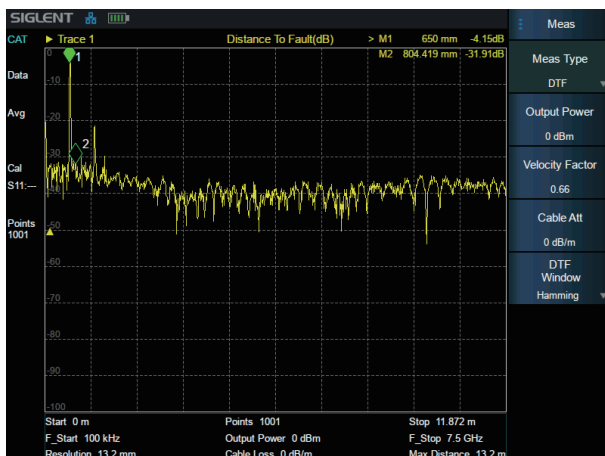



## Model and Main index

Model	SHA851A	SHA852A
Spectrum Analyzer	9 kHz~3.6 GHz	9 kHz~7.5 GHz
Cable and Antenna Test	100 kHz~3.6 GHz	100 kHz~7.5 GHz



## Ordering Information

Product	Description	Order Number
Product code	Spectrum & Vector Network Analyzer, 9 kHz~3.6 GHz	SHA851A
	Spectrum & Vector Network Analyzer, 9 kHz~7.5 GHz	SHA852A
Standard Accessories	Quick Start, USB type-C cable, Power cord, AC-DC adapter, Rechargeable lithium battery, Portable bag	
Options	SHA851A to SHA852A	SHA850-F2
	Source	SHA850-SOR
	Vector Network Analysis	SHA850-VNA
	Advanced Measurement Kit	SHA850-AMK
	Analog Modulation Analysis	SHA850-AMA
	Digital Modulation Analysis	SHA850-DMA
	DC Bias Out	SHA850-BIAS
	GPS Receiver	SHA850-GPS
	GPS Logging(need GPS Receiver)	SHA850-GPSM
General Accessories	Rechargeable lithium battery	10V8_BAT
	AC-DC adapter	12V_AP_4A
	Portable bag	BAG-H2
	GPS antenna, SMA(M), 100 cm	ANT-GPS1
	S5000 Directional Antenna Suit: S5001-VHF (10 MHz~200 MHz), S5001-UHF (200 MHz~500 MHz), S5001-LP (500 MHz~8 GHz), Preamp (10 dB, 9 kHz~8 GHz)	ANT-DA1
	Near field probe kit: 300 kHz~3 GHz, H-field probes (20 mm,10 mm,5 mm), E-field probe (5 mm)	SRF5030T
	Utility Kit: N(M)-SMA(M) cable(6 GHz), N(M)-N(M) cable(6 GHz), N(M)-BNC(F) adaptor x2, N(M)-SMA(F) adaptor x2, 10 dB 1W attenuator	UKitSSA3X
	N(M)-BNC(M) cable, DC~2 GHz, 700 mm	N-BNC-2L
	N(M)-SMA(M) cable, DC~6 GHz, 700 mm	N-SMA-6L
	N(M)-N(M) cable, DC~6 GHz, 700 mm	N-N-6L
	N(M)-N(M) cable ,DC~18 GHz, 1000 mm	N-N-18L
	N(M)-SMA(M) cable ,DC~18 GHz, 1000 mm	N-SMA-18L
	SMA(M)-SMA(M) cable ,DC~18 GHz, 1000 mm	SMA-SMA-18L
	CAT&VNA Accessories	N type Integrated Calibration Kit, Male, DC~9 GHz,50 Ω
N type Integrated Calibration Kit, Female, DC~9 GHz,50 Ω		Y504FS
N type Precision Calibration Kit, DC~9 GHz, 50 Ω		F504TS
3.5 mm type Precision Calibration Kit, DC~9 GHz, 50 Ω		F604TS
VNA Options	2 ports, 9 kHz ~ 4.5 GHz, SMA female	SEM5002A
	2 ports, 9 kHz ~ 9 GHz, SMA female	SEM5012A
	2 ports, 100 kHz ~ 13.5 GHz, 3.5 mm female	SEM5022A
	2 ports, 100 kHz ~ 26.5 GHz, 3.5 mm female	SEM5032A
	4 ports, 9 kHz ~ 4.5 GHz, SMA female	SEM5004A
	4 ports, 9 kHz ~ 9 GHz, SMA female	SEM5014A
	4 ports, 100 kHz ~ 13.5 GHz, 3.5 mm female	SEM5024A
	4 ports, 100 kHz ~ 26.5 GHz, 3.5 mm female	SEM5034A



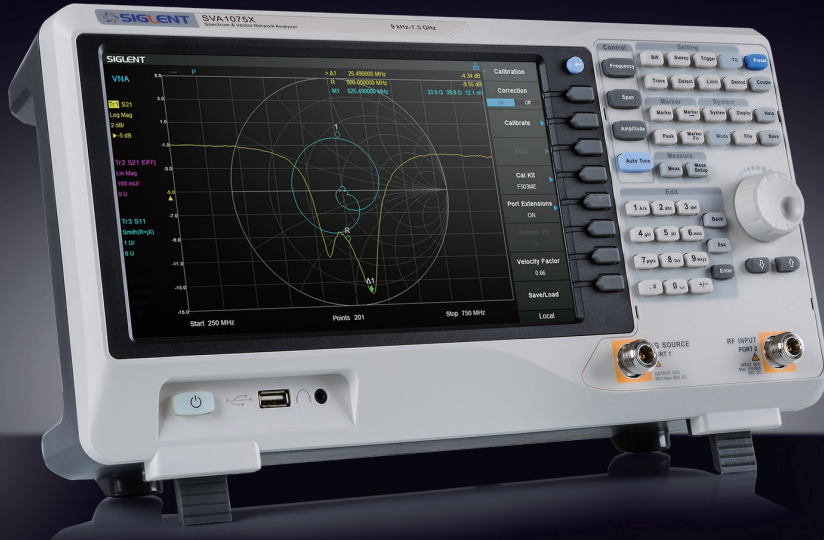

# SVA1000X

## Spectrum & Vector Network Analyzer



### Features and Benefits

- Spectrum Analyzer Frequency Range from 9 kHz up to 7.5 GHz
- Vector Network Analyzer Frequency Range from 100 kHz up to 7.5 GHz
- -165 dBm/Hz Displayed Average Noise Level (Typ.)
- -98 dBc/Hz.@10 kHz Offset Phase Noise (1 GHz, Typ.)
- Level Measurement Uncertainty < 0.7 dB (Typ.)
- 1 Hz Minimum Resolution Bandwidth (RBW)
- Preamplifier Standard
- Tracking Generator Standard
- Distance To Fault (Opt.)
- Vector Signal Modulation Analysis (Opt.)
- EMI Filter and Quasi-Peak Detector Kit (Opt.)
- Advanced Measurement Kit (Opt.)
- 10.1 Inch Multi-Touch Screen , Mouse and Keyboard supported
- Web Browser Remote Control on PC and Mobile Terminals and File Operation



## Design features

### • 10.1 Inch Display with Multi-Touch Screen

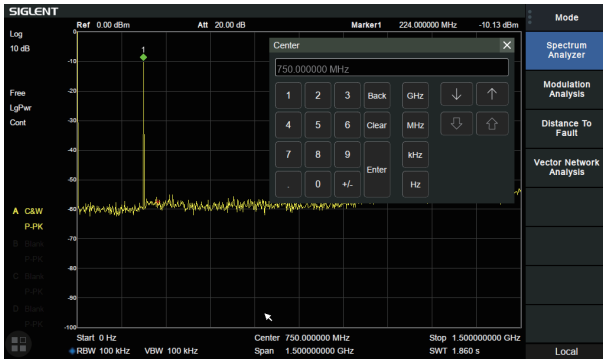

### • Phase noise <math><-98\text{ dBc/Hz}</math>@1 GHz, offset 10 kHz

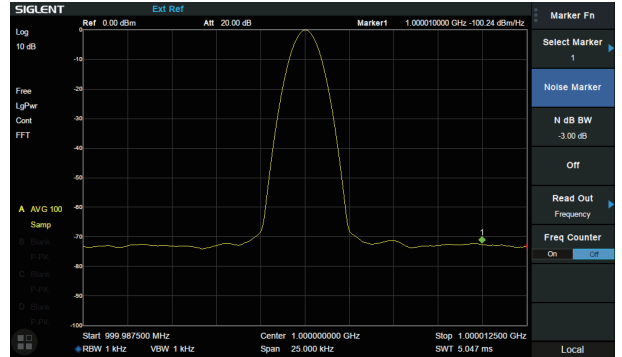

### • Minimum 1 Hz Resolution Bandwidth (RBW)

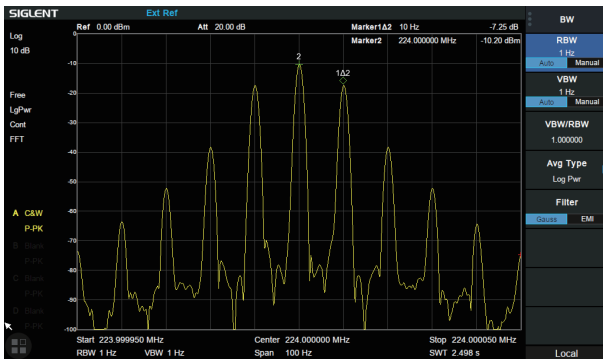

### • ACPR in Advanced Measurement Kit

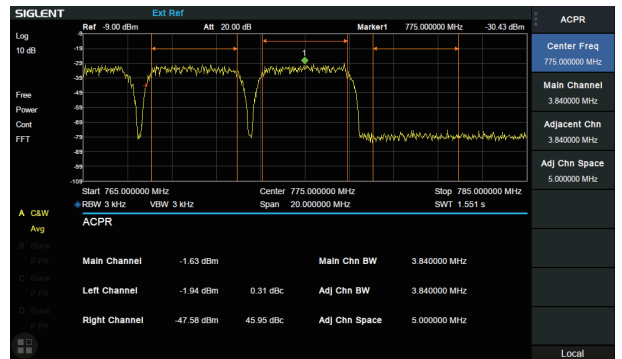

### • -165 dBm/Hz Displayed Average Noise Level

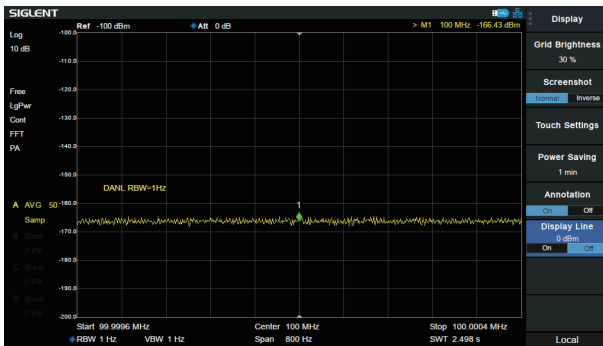

### • Monitor in Advanced Measurement Kit

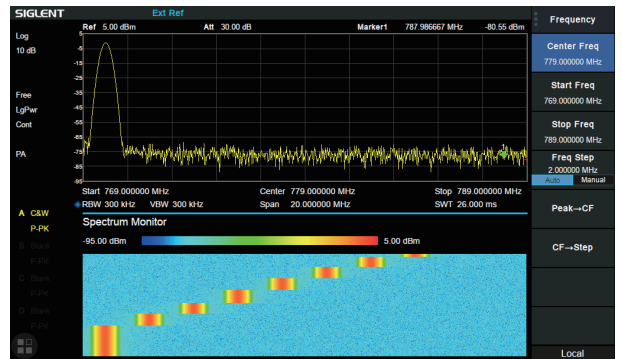

### • 100 k-7.5 GHz Vector S11 and S21 measurement, Multi Formats Overlay Display

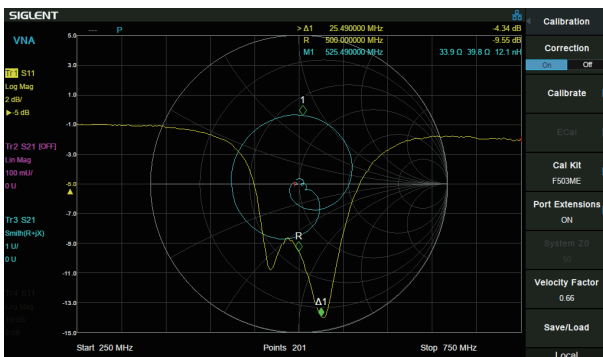

### • Cable and Antenna Test based on Timing Domain Analysis

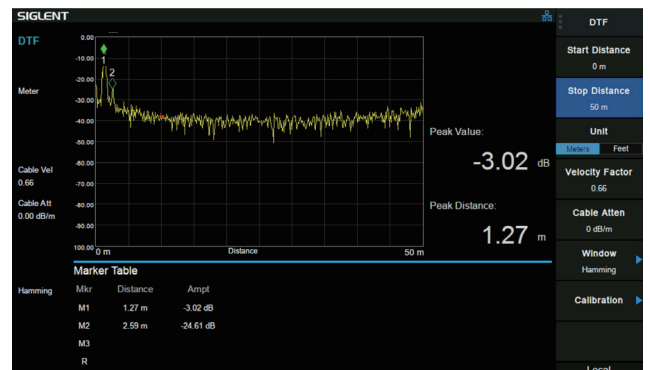

## • Modulation Analysis Mode

AM/FM, ASK/FSK/PSK/MSK/QAM Vector Signal Modulation Analysis, EVM evaluation

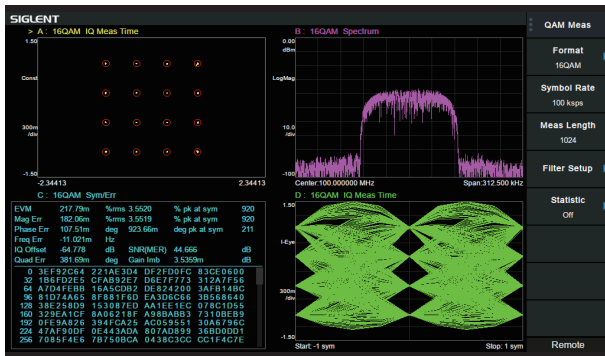

## • EMI Measurement Mode

EMI Measurement with CISPR 16-1-1 EMI filter, Quasi-peak Detector, and pre-stored standards

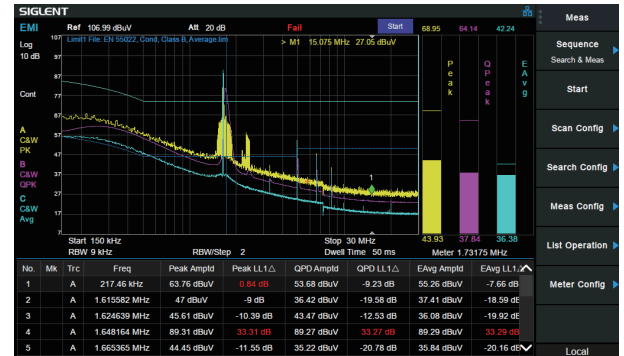

## Model and Main index

Model	SVA1015X	SVA1032X	SVA1075X
Spectrum Analyzer Frequency Range	9 kHz~1.5 GHz	9 kHz~3.2 GHz	9 kHz~7.5 GHz
Vector Network Analyzer Frequency Range	100 kHz~1.5 GHz	100 kHz~3.2 GHz	100 kHz~7.5 GHz
Resolution Bandwidth	1 Hz~1 MHz	1 Hz~1 MHz	1 Hz~3 MHz
Displayed Average Noise Level	-156 dBm/Hz	-161 dBm/Hz	-165 dBm/Hz
SSB Phase Noise	<-99 dBc/Hz	<-98 dBc/Hz	<-98 dBc/Hz
Total Amplitude Accuracy	< 1.2 dB	< 0.7 dB	< 0.7 dB
Tracking Generator	100 kHz~1.5 GHz	100 kHz~3.2 GHz	100 kHz~7.5 GHz
VNA measurement	Vector S11, Vector S21		
Distance to Fault	VNA Timing Domain Analysis Locator		
Touch Screen	Multi Touch, Mouse and Keyboard supported		
Advanced Measurement	CHP, ACPR, OBW, CNR, Harmonic, TOI, Monitor		
Reflection Measurement	VSWR measurement using Reflection Bridge		
EMI Test	EMI Filter and Quasi-Peak Detector, Log Scale and Limit Line		
Modulation Analysis	AM, FM; ASK, FSK, MSK, PSK, QAM		
Communication Interface	LAN, USB Device, USB Host (USB-GPIB)		
Remote Control Capability	SCPI/Labview/IVI based on USB-TMC/VXI-11/Socket/Telnet		
Remote Controller	NI-MAX, Web Browser, Easy Spectrum software, File Explorer		



Ordering Information

Product	Description	Order Number
Product Code	Spectrum & Vector Network Analyzer, 1.5 GHz	SVA1015X
	Spectrum & Vector Network Analyzer, 3.2 GHz	SVA1032X
	Spectrum & Vector Network Analyzer, 7.5 GHz	SVA1075X
Standard Accessories	Quick Start, USB Cable, Power Cord	
Common Options and Accessories	Advanced Measurement Kit	SVA1000X-AMK
	Utility Kit: N (M)-SMA (M) cable (6 GHz), N (M)-N (M) cable (6 GHz), N (M)-BNC (F) adaptor x 2, N (M)-SMA (F) adaptor x 2, 10 dB 1W attenuator	UKitSSA3X
	N (M)-SMA (M) cable, 70 cm, 6 GHz	N-SMA-6L
	N (M)-N (M) cable, 70 cm, 6 GHz	N-N-6L
	N (M)-BNC (M) cable, 70 cm, 2 GHz	N-BNC-2L
	N (M)-N (M) cable, 100 cm, 18 GHz	N-N-18L
	N (M)-SMA (M) cable, 100 cm, 18 GHz	N-SMA-18L
	SMA(M)-SMA(M) cable, 100 cm, 18 GHz	SMA-SMA-18L
	USB-GPIB Adaptor	USB-GPIB
	Soft carrying bag	BAG-S2
	6U Rack Mount Kit	SSA-RMK
	VNA Options	Distance To Fault
Mechanical Calibration Kit: Open (M), Short (M), Match (M,50), Through (F-F), 4.5 GHz, N-Male connector		F503ME
Mechanical Calibration Kit: OSLT, DC - 4.5 GHz, N-Female connector		F503FE
Mechanical Calibration Kit: OSLT, DC - 4.5 GHz, 3.5mm SMA-Male connector		F603ME
Mechanical Calibration Kit: Open (M), Short (M), Match (M,50), Through (F-F), 4.5 GHz, SMA-Female connector		F603FE
Mechanical Calibration Kit: OSLT, DC - 9 GHz, N-Male connector		F504MS
Mechanical Calibration Kit: OSLT, DC - 9 GHz, N-Female connector		F504FS
Mechanical Calibration Kit: OSLT, DC - 9 GHz, 3.5 mm SMA-Male connector		F604MS
Mechanical Calibration Kit: OSLT, DC - 9 GHz, 3.5 mm SMA-Female connector		F604FS
N-type, Male and Female, 50 Ω Calibration Kit, 0~9 GHz		F504TS
3.5 mm, Male and Female, 50 Ω Calibration Kit, 0~9 GHz	F604TS	
EMI test Options	EMI Measurement Kit: EMI Filter and Quasi Peak Detector, EMI Receiver Mode in EasySpectrum Software	SVA1000X-EMI
	300 kHz~3 GHz Near Field Probe Kit: 3 H-probes (20/10/5 mm), 1 E-probe (5 mm)	SRF5030T
Modulation Analysis Options	Digital Modulation: ASK, FSK, MSK, PSK, QAM	SVA1000X-DMA
	Analog Modulation: AM, FM	SVA1000X-AMA
VNA Options	2 ports, 9 kHz ~ 4.5 GHz, SMA female	SEM5002A
	2 ports, 9 kHz ~ 9 GHz, SMA female	SEM5012A
	2 ports, 100 kHz ~ 13.5 GHz, 3.5 mm female	SEM5022A
	2 ports, 100 kHz ~ 26.5 GHz, 3.5 mm female	SEM5032A
	4 ports, 9 kHz ~ 4.5 GHz, SMA female	SEM5004A
	4 ports, 9 kHz ~ 9 GHz, SMA female	SEM5014A
	4 ports, 100 kHz ~ 13.5 GHz, 3.5 mm female	SEM5024A
	4 ports, 100 kHz ~ 26.5 GHz, 3.5 mm female	SEM5034A



# SSG6000A

## RF Signal Generator



### Features and Benefits

- Frequency up to 13.6 GHz/ 20 GHz/ 40GHz
- 0.01 Hz frequency setting resolution
- Level setting range: -130 dBm ~ 24 dBm
- Phase Noise: -135 dBc / Hz @ 1 GHz, 20 kHz offset (typ.)
- Level error  $\leq 0.7$  dB (typ.)
- Provides AM analog modulation with internal, external or Int+Ext source
- Single pulse, double pulse and pulse train generator (option)
- The power meter control kit can easily use the power meter to measure power, control power output and correct line loss
- 5 inch TFT capacitive touch screen, mouse and keyboard supported
- Web browser remote control on PC and mobile terminals
- Standard interface includes USB Host, USB Device (USB TMC), LAN (VXI-11, Socket, Telnet). Optional interface: GPIB



### Design features

#### • LO in Up/Down Converter Measurement

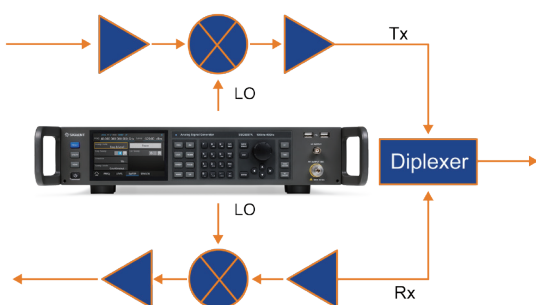

#### • ADC Measurement

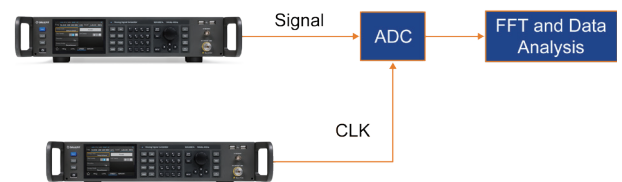

## • DSO Measurement

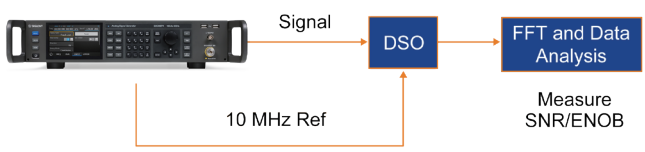

## • DAC Measurement



## • Receiver Blocking Test

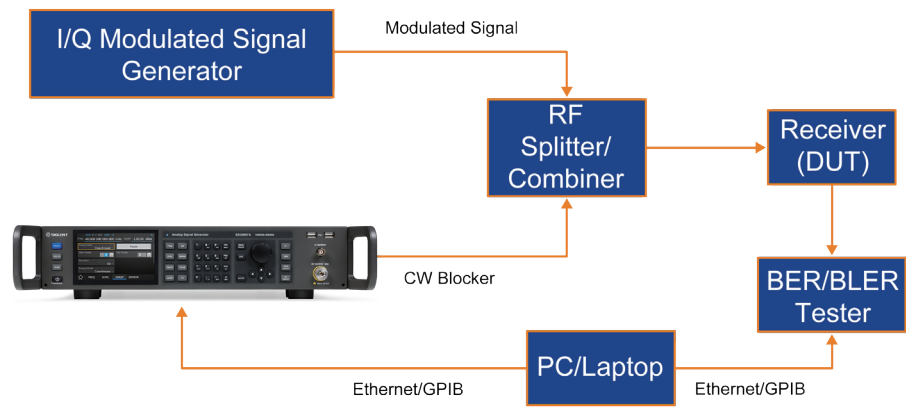

## Model and Main index

Model	SSG6083A	SSG6085A	SSG6087A
Frequency Range	CW MODE 100 kHz~13.6 GHz	CW MODE 100 kHz~20 GHz	CW MODE 100 kHz~40 GHz
Frequency Resolution	0.01 Hz		
Amplitude Resolution	0.01 dB		
Level error	≤ 0.7 dB(typ.)		
Phase noise	-135 dBc/Hz @1 GHz, offset 20 kHz (typ.)		
Display	5 inch capacitance touch screen, RGB (800*480)		



## Ordering Information

Product Description	SSG6000A Signal Generator	Order Number
Product code	Analog Signal Generator 100 kHz~13.6 GHz	SSG6083A
	Analog Signal Generator 100 kHz~20 GHz	SSG6085A
	Analog Signal Generator 100 kHz~40 GHz	SSG6087A
Standard configurations	Quick start, an USB cable, calibration certificate, power cord, 2.92 mm female to female adapter	
option	Pulse modulation	SSG6080A-PU
	Pulse train generator	SSG6080A-PT
	Rack mount kit	SSG6000A-RMK
	USB-GPIB adapter	USB-GPIB
	Upgrade 13.6 GHz to 20 GHz	SSG6080A-F85



# SSG5000A

## RF Signal Generator



### Features and Benefits

- Frequency up to 13.6 GHz / 20 GHz
- 0.001 Hz frequency setting resolution
- Level setting range: -130 dBm ~ 25 dBm
- Phase Noise: -120 dBc / Hz @ 1 GHz, 20 kHz offset (typ.)
- Level error  $\leq 0.7$  dB (typ.)
- Provides AM, FM, PM analog modulation with internal, external or Int+Ext source
- Single pulse, double pulse and pulse train generator (option)
- The power meter control kit can easily use the power meter to measure power, control power output and correct line loss
- 5 inch TFT capacitive touch screen, mouse and keyboard supported
- Web browser remote control on PC and mobile terminals
- Standard interface includes USB Host, USB Device (USB TMC), LAN (VXI-11, Socket, Telnet). Optional interface: GPIB



### Model and Main index

Model	SSG5083A	SSG5085A
Frequency Range	CW MODE 9 kHz~13.6 GHz	CW MODE 9 kHz~20 GHz
Frequency Resolution	0.001 Hz	
Amplitude Resolution	0.01 dB	
Level error	$\leq 0.7$ dB(typ.)	
Phase noise	-120 dBc/Hz @1 GHz, offset 20 kHz (typ.)	
Display	5 inch capacitance touch screen, RGB (800*480)	





## Ordering Information

Product Description	SSG5000A Signal Generator	Order Number
Product code	Analog Signal Generator 9 kHz~13.6 GHz	SSG5083A
	Analog Signal Generator 9 kHz~20 GHz	SSG5085A
Standard configurations	Quick start, an USB cable, calibration certificate, power cord	
option	Pulse modulation	SSG5080A-PU
	Pulse train generator	SSG5080A-PT
	110 dB Attenuator module <sup>[1]</sup>	SSG5080A-LP
	Rack mount kit	SSG-RMK
	USB-GPIB adapter	USB-GPIB
	Upgrade 13.6 GHz to 20 GHz	SSG5080A-F85

[1] Assembled and calibrated in factory only



# SSG5000X

## RF Signal Generator



### Features and Benefits

- Frequency up to 4 GHz/6 GHz
- 0.001 Hz frequency setting resolution
- High output power up to +26 dBm (typ.)
- Phase Noise: -120 dBc/ Hz @ 1 GHz, 20 kHz offset (typ.)
- User flatness correction with power sensor to correct the cable loss
- Provides AM, FM, PM analog modulation with internal, external or Int+Ext source
- Single pulse, double pulse and Pulse train generator (option)
- Internal IQ modulation with 150 MHz modulation bandwidth with perfect in-factory calibration
- Internal include some digital communication stand file such as 5G-NR, LTE, WCDMA, WLAN, and playback them
- Internal Custom mode generate common IQ signal such as QAM, FSK, ASK, MSK
- Analog differential I/Q outputs
- External analog I/Q input
- USB-power meter measurement
- 5 inch TFT capacitive touch screen, mouse and keyboard supported
- Web browser remote control on PC and mobile terminals
- Standard interface included USB Host, USB Device (USB TMC), LAN (VXI-11, Socket, Telnet). Optional interface: GPIB

 Design features

• Double pulse modulation

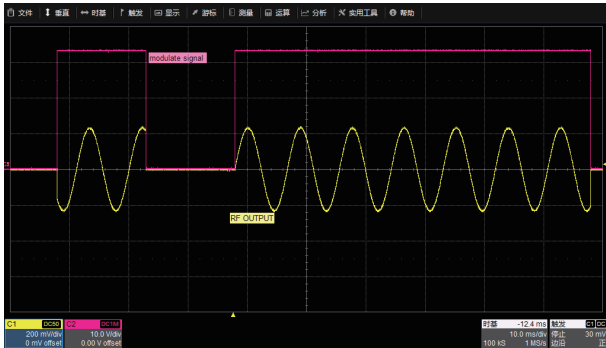

• Pulse train generator

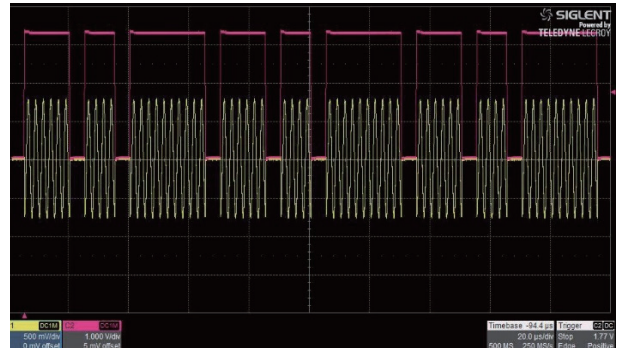

• Works with Power sensor to use the measured values to compensate the cable losses with internal control functions

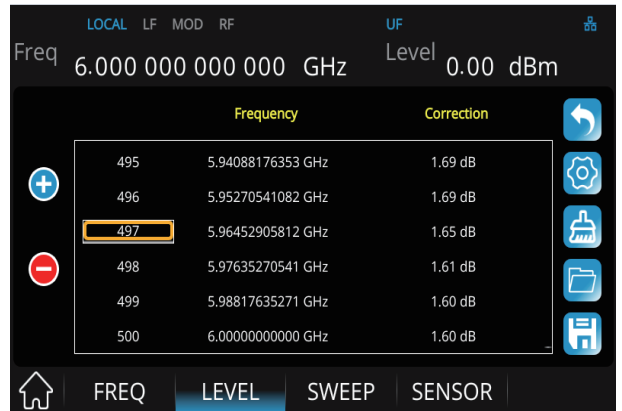
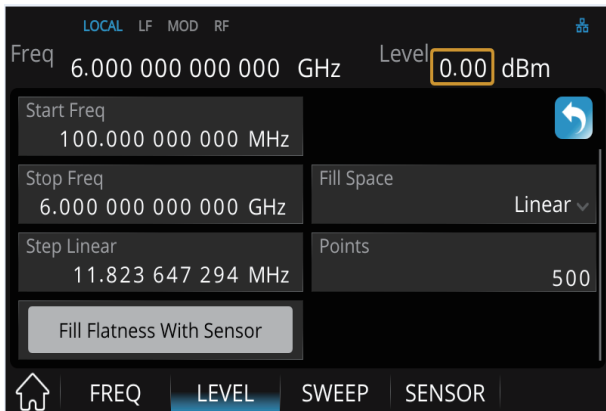

• Custom mod can generate IQ modulated signal such as QAM, PSK, ASK, FSK, the maximum sample rate is 120 Msps/s

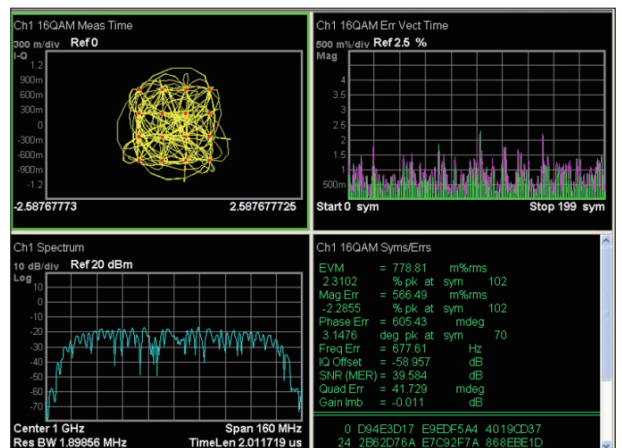
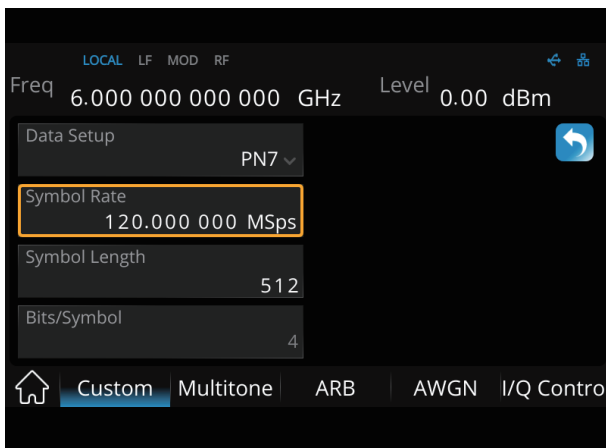

- Multi-tone mode to output multi-signal

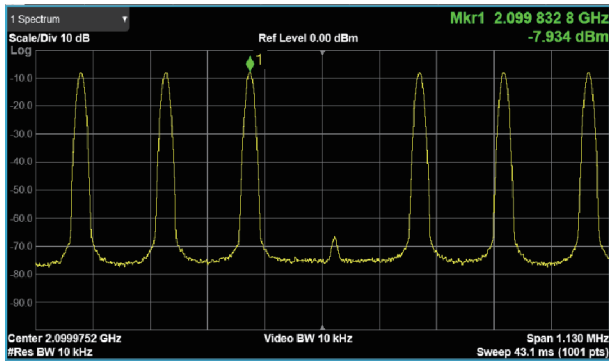

- ARB mode to build and replay waveform sequence

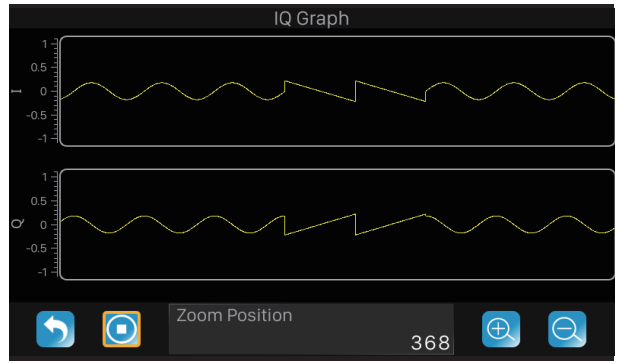

- Arb mode to replay back communication stand files

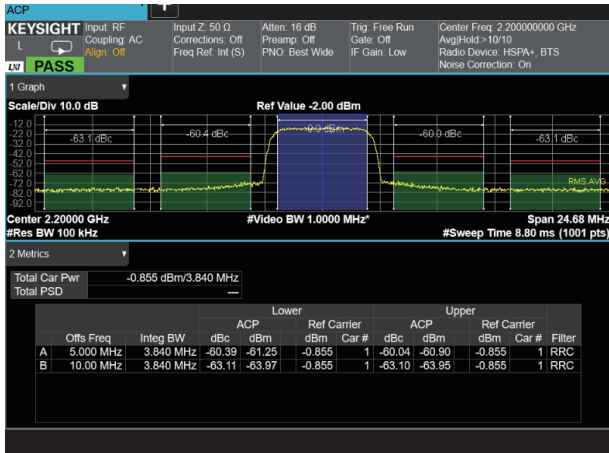

3 GPP WCDMA TM 1-64 DPCH ACPR

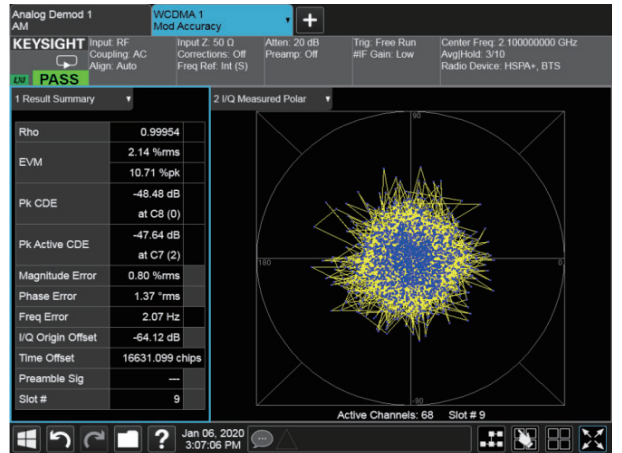

3 GPP WCDMA TM 1-64 DPCH EVM

- ARB mod to generate multi-carrier

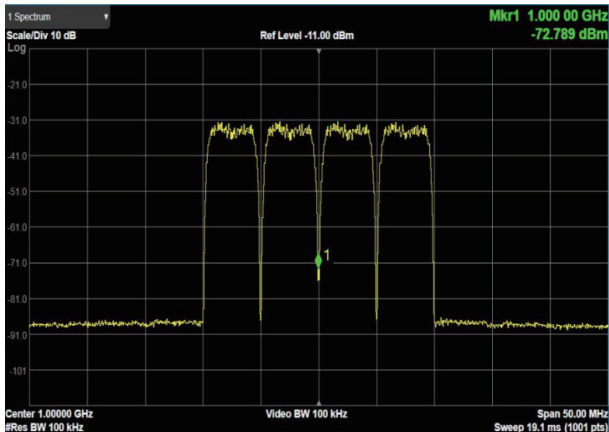

- ARB mod to use the marker to label symbol of the waveform files and simultaneously output a pulse from the invent interface, this can synchronize another device.

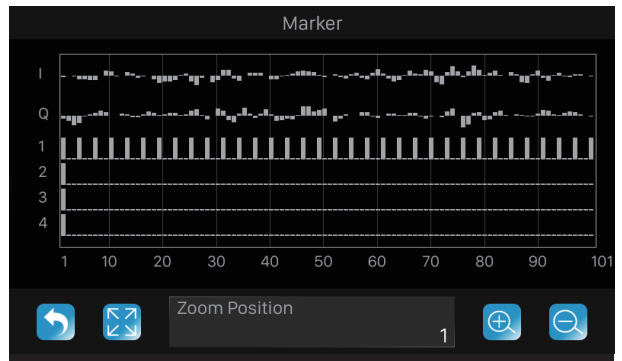

- ARB mode to add real time AWGN to the digital IQ to satisfy the receiver performance tests of receiver

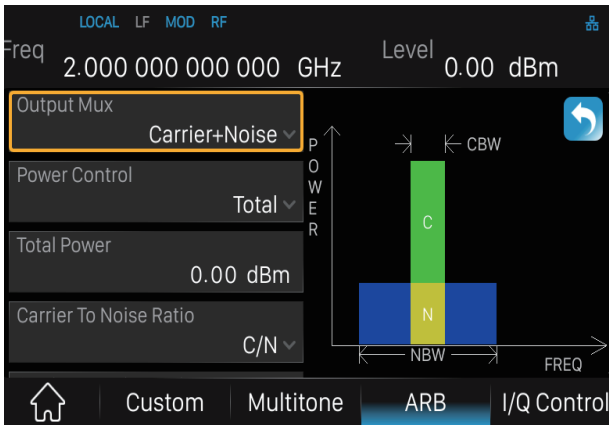

- ARB mod to clip the signal of the peak power and display the CCDF (cytotoxic cell differentiation factor)

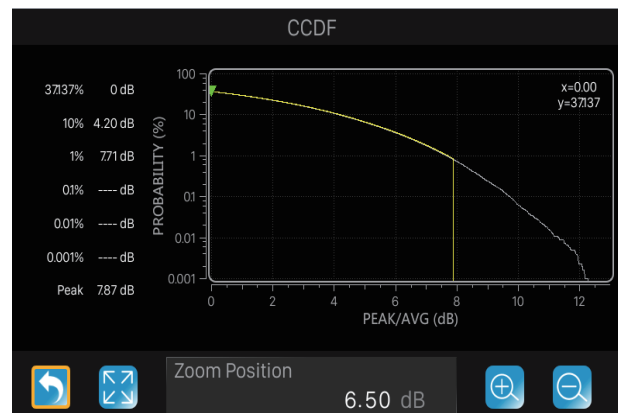
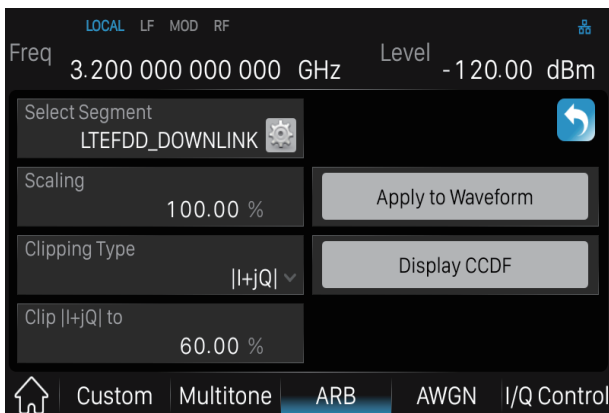

### • SigIQPro Signal Generation Software (Optional)

SigIQPro is a flexible PC-based signal generation software that takes signal generation to a whole new level, making it easy to generate complex signals that are fully compliant with Bluetooth, IoT and other communication standards. SIGLENT instruments and SigIQPro signal generation software integrate simulation, design and test to easily meet the needs of users at all stages of design, R&D, and production



## Model and Main index

Model	SSG5040X	SSG5060X	SSG5040X-V	SSG5060X-V
Frequency Range	CW MODE 9 kHz~4 GHz	CW MODE 9 kHz~6 GHz	CW MODE 9 kHz~4 GHz	CW MODE 9 kHz~6 GHz
			IQ MODE 10 MHz~4 GHz	IQ MODE 10 MHz~6 GHz
Frequency Resolution	0.001 Hz			
Amplitude Resolution	0.01 dB			
Phase noise	-120 dBc/Hz @1 GHz, offset 20 kHz (typ.)			
Display	5 inch capacitance touch screen, RGB (800*480)			



## Ordering Information

Product Description	SSG5000X Signal Generator	Order Number
Product code	Analog Signal Generator 9 kHz ~ 4 GHz	SSG5040X
	Analog Signal Generator 9 kHz ~ 6 GHz	SSG5060X
	Vector Signal Generator 10 MHz ~ 4 GHz	SSG5040X-V
	Vector Signal Generator 10 MHz ~ 6 GHz	SSG5060X-V
Standard configurations	Quick start, an USB cable, calibration certificate, power cord	
option	Pulse train generator	SSG5000X-PT
	Rack mount kit	SSG-RMK
	USB-GPIB adapter	USB-GPIB
	Upgrade 4 GHz to 6 GHz	SSG5000X_F60
	Upgrade IQ bandwidth from 75 MHz to 150 MHz	SSG5000XV_B150
	Precision Frequency Reference	10M_OCXO_L <sup>[1]</sup>
	Generate IOT waveform at device	SSG5000XV-IOT
	SigIQPro for Bluetooth waveform playback license <sup>[2]</sup>	SigIQPro-BT
	SigIQPro for IOT waveform playback license	SigIQPro-IOT
SigIQPro for OFDM waveform playback license	SigIQPro-OFDM	

[1] Assembled and calibrated in factory only

[2] See the SigIQPro User Manual for details

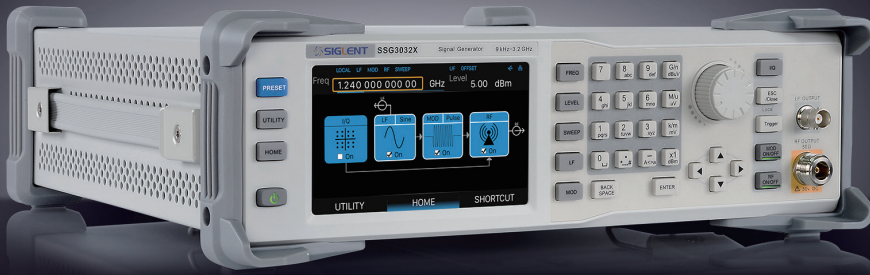

# SSG3000X

## RF Signal Generator



### Features and Benefits

- Frequency up to 2.1 GHz/3.2 GHz
- 0.01 Hz frequency setting resolution
- Level output from -110 dBm to +13 dBm
- Maximum level up to +20 dBm (typ.)
- Phase Noise: -110 dBc/ Hz @ 1 GHz , 20 kHz offset (typ.)
- Level accuracy  $\leq 0.7$  dB (typ.)
- Provides AM, FM & PM analog modulation with internal, external or Int+Ext source
- Pulse modulation, on/off ratio  $\geq 70$  dBc
- Pulse train generator (option)
- External IQ modulation with SDG6000X as the baseband IQ signal
- USB-power meter measurement
- 5 inch TFT capacitive touch screen, mouse and keyboard supported
- Web browser remote control on PC and mobile terminals
- Standard interface include USB Host, USB Device (USB TMC), LAN (VXI-11, Socket, Telnet). Optional interface: GPIB



### Design features

#### • Double pulse modulation

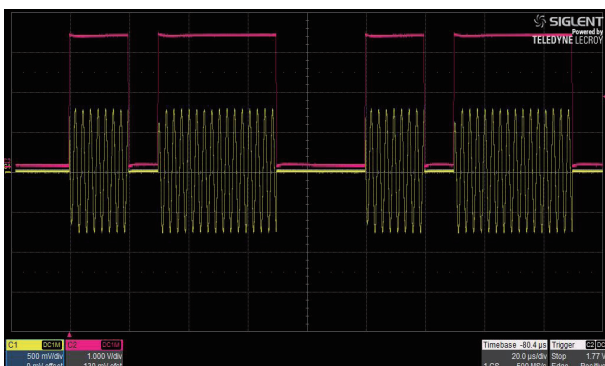

#### • Pulse train generator

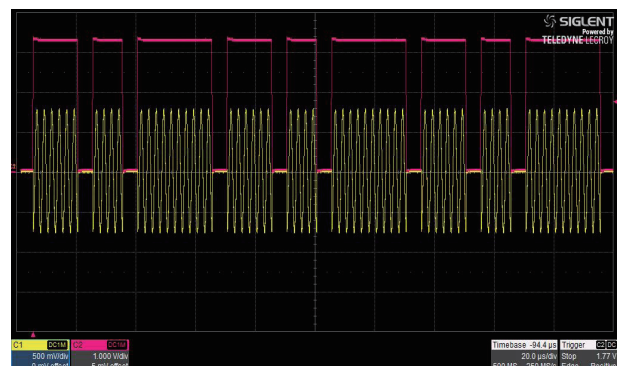

- Provides double-tone signal with IQ modulation, easily do TOI testing

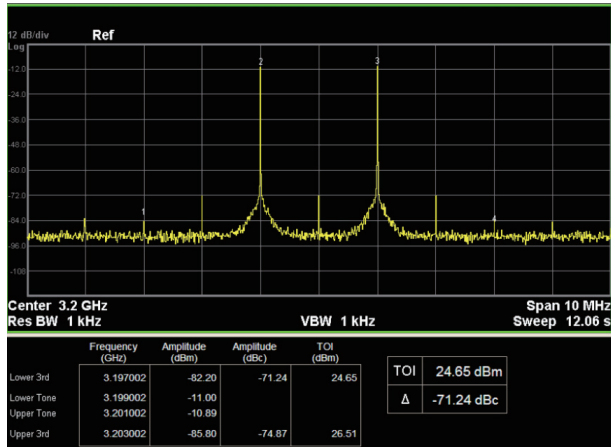

- Maximum output level up to +20 dBm

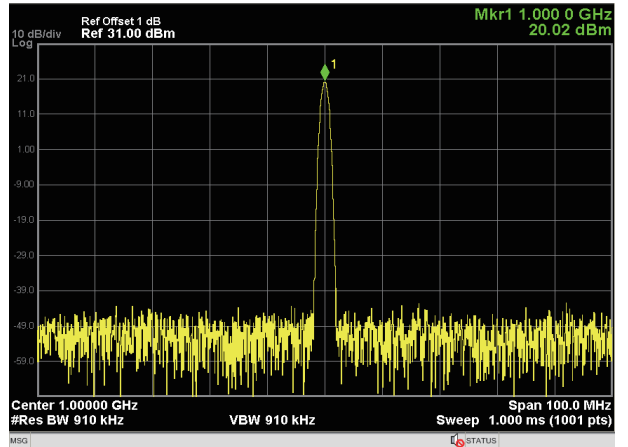

- Power output display using USB power sensor

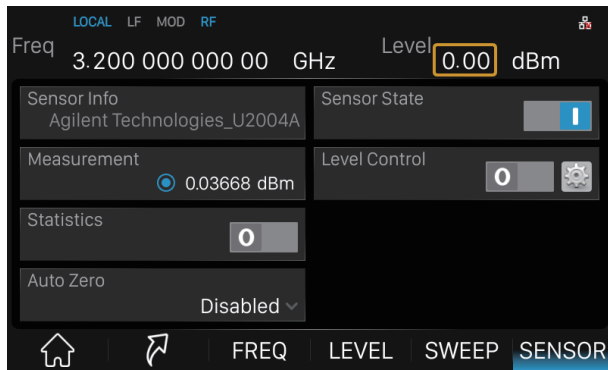

- Power output control using USB power sensor

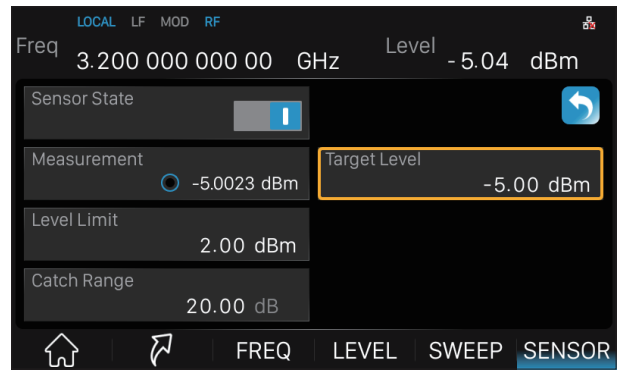

- Example for auto level control





- External IQ modulation using the SDG6000X as the baseband source

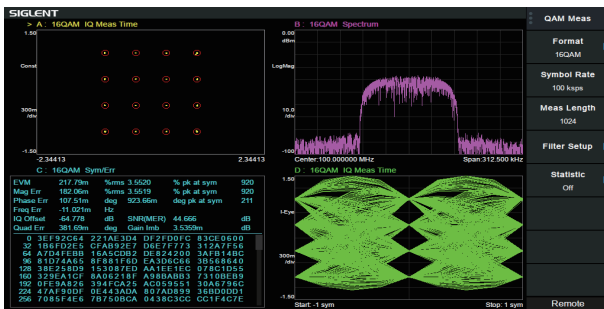

- 5 inch touch screen, keyboard and mouse support

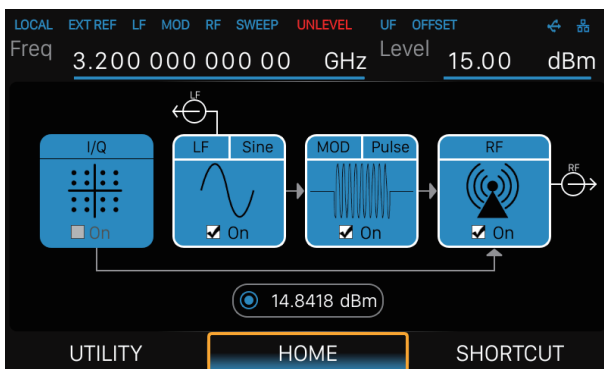

## Specifications

Specifications are valid under the following condition: The instrument is within the calibration period, has been stored between 0 and 50°C for at least 2 hours prior to use, and has been powered on and warmed up for at least 40 minutes. The specifications include the measurement uncertainty, unless otherwise noted.

**Specifications:** All products are guaranteed to meet published specifications when operating temperatures from 5 to 45°C, unless otherwise noted.

**Typical(typ.):** Performance deemed typical implies that 80 percent of the measurement results will meet the typical published performance with a 95th percentile confidence level at room temperature (approximately 25°C). Typical performance is not warranted and does not include measurement uncertainty.

**Nominal(nom.):** This value indicates the expected mean or average performance, or an attribute whose performance is by design, such as the 50 ohm connector.















## Model and Main index





Model	SSG3021X	SSG3032X	SSG3021X-IQE	SSG3032X-IQE
Frequency Range	CW MODE 9 kHz~2.1 GHz	CW MODE 9 kHz~3.2 GHz	CW MODE 9 kHz~2.1 GHz IQ MODE 10 MHz~2.1 GHz	CW MODE 9 kHz~3.2 GHz IQ MODE 10 MHz~3.2 GHz
Frequency Resolution	0.01 Hz			
Amplitude Resolution	0.01 dB			
Level accuracy	0.7 dB (typ.)			
Phase noise	-110 dBc/Hz @1 GHz ,offset 20 kHz (typ.)			
Display	5 inch capacitance touch screen, RGB (800*480)			









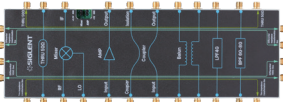

## Ordering Information



Product Description	SSG3000X Signal Generator	Order Number
Product code	Signal Generator 9 kHz~2.1 GHz	SSG3021X
		SSG3021X-IQE
	Signal Generator 9 kHz~3.2 GHz	SSG3032X
		SSG3032X-IQE
Standard configurations	quick start, an USB cable, calibration certificate, power cord	
option	pulse train generator	SSG3000X-PT
	rack mount kit	SSG-RMK
	USB-GPIB adapter	USB-GPIB
	Upgrade 2.1 GHz to 3.2 GHz	SSG3000X-21BW32
	Upgrade 2.1 GHz to 3.2 GHz (with external IQ)	SSG3000X-IQE-21BW32

Type	Model	Picture	Specifications
<b>Near-field Probe</b>	SRF5030T		Near Field Probe: H field probe sets (20 mm, 10 mm, 5 mm) , E field probe (5 mm), 300 kHz~3.0 GHz; distinguished within 10 cm range of the magnetic field; for EMI radiation interference and the intensity detector
<b>GPIB</b>	USB-GPIB Adapter		The USB Device interface extends into the GPIB interface, USB-GPIB adapter can more easily complete the task of the operation command through the GPIB, USB follow the USB2.0 specification, GPIB follow the IEEE488.2 standard
<b>Cable</b>	N-BNC-2L		N-BNC cable for SSA3000X Series; 2 GHz bandwidth
	N-N-6L		N-N cable for SSA3000X, SSA3000X Plus, SSA3000X-R, SVA1000X Series; 6 GHz bandwidth
	N-SMA-6L		N-SMA cable for SSA3000X, SSA3000X Plus, SSA3000X-R, SVA1000X Series; 6 GHz bandwidth
	N-N-18L		N(M)-N(M) cable for SSA3000X, SSA3000X Plus, SSA3000X-R, SVA1000X series, 100 cm, 18 GHz bandwidth
	N-SMA-18L		N(M)-SMA(M) cable for SSA3000X, SSA3000X Plus, SSA3000X-R, SVA1000X series, 100 cm, 18 GHz bandwidth
	SMA-SMA-18L		SMA(M)-SMA(M) cable, 18 GHz
	SMA-SMA-26L		SMA(M)-SMA(M) cable, 26 GHz
	SMAF-SMA-26L		SMA(F)-SMA(M) cable, 26 GHz
	2.92F-2.92F-40A		2.92 mm Female - 2.92 mm Female adaptor, 40 GHz
	V26-N35MN35F-25IN		NMD 3.5 mm(M) – NMD 3.5 mm(F), 26.5 GHz
	V26-N35FA35F-25IN		NMD 3.5 mm(F) – APC 3.5 mm(F), 26.5 GHz

Type	Model	Picture	Specifications
Reflection Bridge	RB3X25		VSWR bridge: (1 MHz~2.5 GHz), N (M) -N (M) adaptor (2 pcs)
Utility Kit	UKitSSA3X		Utility Kit for SSA3000X Series: N (M) -SMA (M) cable, N (M) -N (M) cable, N (M) -BNC (F) adaptor (2 pcs), N (M) -SMA (F) adaptor (2 pcs), 10 dB attenuator
VNA Calibration Kit	F503ME		Mechanical Calibration Kit: Open (M), Short (M), Match (M,50), Through (F-F), 4.5 GHz
	F503FE		Mechanical Calibration Kit: OSLT, DC - 4.5 GHz, N-Female connector
	F504MS		Mechanical Calibration Kit: OSLT, DC - 9 GHz, N-Male connector
	F504FS		Mechanical Calibration Kit: OSLT, DC - 9 GHz, N-Female connector
	F504TS		N-type, Male and Female, 50 Ω Calibration Kit, 0~9 GHz
	F505TS		Mechanical Calibration Kit: OSLT, DC - 18 GHz, N-Male and Female connector
	F603ME		Mechanical Calibration Kit: OSLT, DC - 4.5 GHz, 3.5 mm SMA-Male connector
	F603FE	Mechanical Calibration Kit: Open (M), Short (M), Match (M,50), Through (F-F), 4.5 GHz, SMA-type	
	F604MS		Mechanical Calibration Kit: OSLT, DC - 9 GHz, 3.5 mm SMA-Male connector
	F604FS		Mechanical Calibration Kit: OSLT, DC - 9 GHz, 3.5 mm SMA-Female connector
	F604TS		3.5 mm, Male and Female, 50 Ω Calibration Kit, 0~9 GHz
	F604TY	Mechanical Calibration Kit: OSLT, DC - 27 GHz, 3.5 mm-Male and Female connector	
	Y504MS		Integrated Mechanical Calibration Kit: OSLT, DC - 9 GHz, N-Male
	Y504FS		Integrated Mechanical Calibration Kit: OSLT, DC - 9 GHz, N-Female

Type	Model	Picture	Specifications
Rack Mount	SSA-RMK		Rackmount kit , compatible with the SSA3000X,SSA3000X Plus, SVA1000X,SSA3000X-R model; Height 6U
	SSG-RMK		Rack Mount kit; SSG3000X, SSG5000X, SSG5000A, SDG7000A; Height 3U
	SSG6000A-RMK		Rack Mount kit; SSG6000A; Height 2U
RF Test board	SNA-TB01		Board integrated with RF components like amplifier, mixer, filter for vector network analyzer demonstration
Rechargeable lithium battery	10V8_BAT		10.8V, 74 Wh
Antenna	ANT-GPS1		GPS antenna, SMA(M), 100 cm
	ANT-DA1		Directional Antenna Suit, N type, ANT-DA11 antenna (10 MHz~200 MHz), ANT-DA12 antenna (200 MHz~500 MHz), ANT-DA13 antenna (500 MHz~8 GHz), Amplifier handle 12dB@1GHz(typ.)
	ANT-DA11		Contains amplifier handle and 10 MHz ~ 200 MHz antenna. Antenna gain 10 dB (typical value); SWR <1:1.9 (typical value); 50 Ω/N type, female; polarization direction horizontal and vertical
	ANT-DA12		Contains amplifier handle and 200 MHz ~ 500 MHz antenna. Antenna gain 10 dB (typical value); SWR <1:1.9 (typical value); 50 Ω/N type, female; polarization direction horizontal and vertical
	ANT-DA13		Contains amplifier handle and 500 MHz ~ 8 GHz antenna. Antenna gain 10 dB (typical value); SWR <1:1.9 (typical value); 50 Ω/N type, female; polarization direction horizontal and vertical
TDR Probe	ADP-18		Adjustable differential TDR probe DC~18 GHz
	ADP-26		Adjustable differential TDR probe DC~26.5 GHz
	ASP-18		Adjustable single-end TDR probe DC~18 GHz
	ASP-26		Adjustable single-end TDR probe DC~26.5 GHz

Type	Model	Picture	Specifications
AC-DC adapter	12V_AP_4A		12V, 4A
Carry Bag	BAG-S2		Soft Carry Case for SDS2000X, SDS5000X, SSA3000X, SVA1000X, SSA3000X Plus
	BAG-H2		Soft Carry Case for SHA850A, SHN900A
VNA Calibration Kit	SEM5002A		2 ports, 9 kHz ~ 4.5 GHz, SMA female
	SEM5012A		2 ports, 9 kHz ~ 9 GHz, SMA female
	SEM5022A		2 ports, 100 kHz ~ 13.5 GHz, 3.5 mm female
	SEM5032A		2 ports, 100 kHz ~ 26.5 GHz, 3.5 mm female
	SEM5004A		4 ports, 9 kHz ~ 4.5 GHz, SMA female
	SEM5014A		4 ports, 9 kHz ~ 9 GHz, SMA female
	SEM5024A		4 ports, 100 kHz ~ 13.5 GHz, 3.5 mm female
	SEM5034A		4 ports, 100 kHz ~ 26.5 GHz, 3.5 mm female
Switch Matrix	SSM5122A		2 input ports, 12 output ports, 3.5 mm female, 9 kHz ~ 9 GHz
	SSM5124A		2 input ports, 24 output ports, 3.5 mm female, 9 kHz ~ 9 GHz
	SSM5142A		4 input ports, 12 output ports, 3.5 mm female, 9 kHz ~ 9 GHz
	SSM5144A		4 input ports, 24 output ports, 3.5 mm female, 9 kHz ~ 9 GHz
	SSM5321A		2 input ports, 6 output ports, 3.5 mm female, 100 kHz ~ 26.5 GHz
	SSM5342A		4 input ports, 12 output ports, 3.5 mm female, 100 kHz ~ 26.5 GHz

Type	Model	Picture	Specifications
<b>Mechanical Switch</b>	SSU5181A		DC ~ 18 GHz, including one SPDT mechanical switch, SMA female
	SSU5182A		DC ~ 18 GHz, including two SPDT mechanical switches, SMA female
	SSU5183A		DC ~ 18 GHz, including three SPDT mechanical switches, SMA female
	SSU5184A		DC ~ 18 GHz, including four SPDT mechanical switches, SMA female
	SSU5261A		DC ~ 26.5 GHz, including one SPDT mechanical switch, SMA female
	SSU5262A		DC ~ 26.5 GHz, including two SPDT mechanical switches, SMA female
	SSU5263A		DC ~ 26.5 GHz, including three SPDT mechanical switches, SMA female
	SSU5264A		DC ~ 26.5 GHz, including four SPDT mechanical switches, SMA female
	SSU5265A		DC ~ 26.5 GHz, including one SP6T mechanical switch, SMA female
	SSU5266A		DC ~ 26.5 GHz, including two SP6T mechanical switches, SMA female
	SSU5501A		DC ~ 50 GHz, including one SPDT mechanical switch, 2.4 mm female
	SSU5502A		DC ~ 50 GHz, including two SPDT mechanical switches, 2.4 mm female
	SSU5503A		DC ~ 50 GHz, including three SPDT mechanical switches, 2.4 mm female
	SSU5504A		DC ~ 50 GHz, including four SPDT mechanical switches, 2.4 mm female
<b>PC Software</b>	SigIQPro		A comprehensive PC-based software for general and standards-based signals creation, supporting Bluetooth, IoT, Custom OFDM, etc
<b>Noise Source Driver</b>	NSD28		Noise source driver, connect spectrum analyzer to noise source

## Other Products Overview

SIGLENT also provides other instruments like Oscilloscopes, AWG, Multimeters, Electronic loads, power supplies.

### ※ Oscilloscopes ※



	SDS7000A	SDS6000A	SDS6000L	SDS5000X	SDS3000X HD	SDS2000X HD	SDS2000X plus
Bandwidth	3 GHz ~ 4 GHz	350 MHz ~ 2 GHz	500 MHz ~ 2 GHz	350 MHz ~ 1 GHz	350 MHz ~ 1 GHz	100 MHz ~ 350 MHz	100 MHz ~ 500 MHz
Sample rate	20 GSa/s	5 GSa/s (10 GSa/s ESR)	5 GSa/s (10 GSa/s ESR)	5 GSa/s	4 GSa/s	2 GSa/s	2 GSa/s
Analog channel	4	4	4/8	4	4	4	2/4
Memory depth	1 Gpts	500 Mpts	500 Mpts	250 Mpts	400 Mpts	200 Mpts	200 Mpts
Waveform update Rate	1,100,000 wfm/s	750,000 wfm/s	750,000 wfm/s	500,000 wfm/s	890,000 wfm/s	500,000 wfm/s	500,000 wfm/s
Protocol analysis	Standard: I2C, SPI, UART, CAN, LIN Optional: CAN FD, FlexRay, I2S, MIL-STD-1553B, SENT, Manchester (decode only), ARINC429(only SDS7000A, SDS6000A, SDS5000A, SDS3000X HD)						
Sequence	Yes	Yes	Yes	Yes	Yes	Yes	Yes
History	Yes	Yes	Yes	Yes	Yes	Yes	Yes
Math traces	4	4	4	2	4	2	2
FFT points	32 Mpts	8 Mpts	8 Mpts	2 Mpts	4 Mpts	2 Mpts	2 Mpts
Search and Navigate	Yes	Yes	Yes	Yes	Yes	Yes	Yes
DVM	Yes	Yes	Yes	Yes	Yes	Yes	
Counter	Yes	Yes	Yes	Yes	Yes	Yes	Yes
Histogram	Yes	Yes	Yes	Yes	Yes	Yes	Yes
Bode plot	Yes	Yes	Yes	Yes	Yes	Yes	Yes
Power analysis	Yes	Yes	Yes	Yes	Yes	Yes	Yes
Eye/Jitter analysis	Yes	Yes	Yes				
Compliance Test	Yes						
Digital channels	Yes	Yes	Yes	Yes	Yes	Yes	Yes
AWG	50 MHz	25 MHz	25 MHz	25 MHz	50 MHz	25 MHz	50 MHz
Zone Trigger	Yes	Yes	Yes	Yes	Yes	Yes	Yes
Webserver	Yes	Yes	Yes	Yes	Yes	Yes	Yes
HDMI output	Yes	Yes	Yes				
Porbe Adapters	Yes	Yes	Yes	Yes	Yes		
Screen	15.6" touch	12.1" touch	None	10.1" touch	10.1" touch	10.1" touch	10.1" touch



	SDS2000X-E	SDS1000X HD	SDS800X HD	SDS1000X-E	SDS1104X-U	SDS1000CML+	
Bandwidth	200 MHz ~ 350 MHz	100 MHz ~200 MHz	70 MHz ~200 MHz	100 MHz ~ 200 MHz	100 MHz	70 MHz ~ 150 MHz	
Sample rate	2 GSa/s	2 GSa/s	2 GSa/s	1 GSa/s	1 GSa/s	1 GSa/s	
Analog channel	2	2/4	2/4	2/4	4	2	
Memory depth	28 Mpts	100 Mpts	100/50 Mpts	14 Mpts	14 Mpts	2 Mpts	
Waveform update Rate	400,000 wfm/s	500,000 wfm/s	500,000 wfm/s	400,000 wfm/s	400,000 wfm/s		
Protocol analysis	I2C, SPI, UART, CAN, LIN	I2C, SPI, UART, CAN, LIN, CAN FD(Decode Only), FlexRay(Decode Only)	I2C, SPI, UART, CAN, LIN				
Sequence	Yes	Yes	Yes	Yes	Yes		
History	Yes	Yes	Yes	Yes	Yes		
Math traces	1	4	4	1	1	1	
FFT points	1 Mpts	2 Mpts	2 Mpts	1 Mpts	128 kpts		
Search and Navigate	Yes	Yes	Yes	Yes	Yes		
DVM							
Counter		Yes	Yes				
Histogram							
Bode plot	Yes	Yes	Yes	Yes			
Power analysis		Yes	Yes				
Eye/Jitter analysis							
Digital channels	Yes	Yes	Yes	Yes			
AWG	25 MHz	25 MHz	25 MHz	25 MHz			
Zone Trigger							
Websvr	Yes	Yes	Yes	Yes			
HDMI output							
Probe Adapters							
Screen	7" LCD	10.1" touch	7" touch	7" LCD	7" LCD	7" LCD	

## ※ Arbitrary Waveform Generator ※



	SDG7000A	SDG6000X	SDG2000X	SDG1000X	SDG800
Bandwidth	350/500 MHz, 1 GHz	200/300/500 MHz	40/80/120 MHz	30/60 MHz	5/10/30 MHz
Number of channels	2 Differential/ Single-ended	2 Single-ended	2 Single-ended	2 Single-ended	1 Single-ended
Output range	± 24 V (48 V)	±10V	±10V	±10V	±10V
Digital bus(Optional)	16-bit, LVTTTL or LVDS output Bit rate 1μbps ~ 1 Gbps				
Sampling rate	5 GSa/s	2.4 GSa/s (2X Interpolation)	1.2 GSa/s (4X Interpolation)	150 MSa/s	125MSa/s
Vertical resolution	14-bit	16-bit	16-bit	14-bit	14-bit
Arbitrary waveform length	24 pts ~ 512 Mpts/ch	2 ~ 20 Mpts	8 ~ 8 Mpts	16 kpts	16 kpts
Modulation types	AM, FM, PM, PWM, FSK, PSK, ASK, QAM	AM,FM,PM,ASK,FSK,PSK, PWM, QAM	AM,FM,PM,ASK,FSK,PSK, PWM	AM, DSB-AM, FM,PM, FSK, ASK, PSK, PWM	AM, DSB-AM, FM, PM, FSK, ASK, PWM
Harmonic output	16	10	10	16	
Sweep & Burst	Yes	Yes	Yes	Yes	Yes
IQ Signal Generator	Yes	Yes			
PRBS Generator	Yes	Yes			
Display	5" touch screen , 800*480	4.3" touch screen, 480*272	4.3" touch screen, 480*272	4.3" LCD, 480*272	3.5" LCD, 320*240



## ※ Power Supply ※

	SPS5000X	SPD3000X	SPD3303C	SPD1000X
Output Channel	1/2/3	3	3	1
Max. Voltage	40/50/80/160 V	32 V	32 V	16/30 V
Max. Current	7.5/15/22.5/30/45/60/90 A	3.2 A	3.2 A	5/ 8 A
Max. Power	180/360/720/1080 W	220 W	220 W	128/150 W
Resolution	1 mV/1 mA	1 mV/1 mA	10 mV/10 mA	1 mV / 1 mA
Screen	2.4" OLED	4.3" LCD	LED	2.8" LCD

## ※ DC Electronic Load ※

	SDL1020X	SDL1020X-E	SDL1030X	SDL1030X-E
Min. readback resolution	0.1 mV, 0.1 mA	1 mV, 1 mA	0.1 mV, 0.1 mA	1 mV, 1 mA
Input power	200 W		300 W	
Input current	30 A			
Input voltage	150 V			
CC Dynamic mode frequency	25 kHz			
Current slew rate	0.001 A/us~2.5 A/us			
Display	3.5 inch TFT-LCD display			

## ※ Digital Multimeter ※

	SDM3045X	SDM3055	SDM3065X
Reading resolution	4 1/2	5 1/2	6 1/2
DC voltage	600 mV ~ 1000 V	200 mV ~ 1000 V	200 mV ~ 1000 V
AC voltage	600 mV ~ 750 V	200 mV ~ 750 V	200 mV ~ 750 V
DC current	600 $\mu$ A ~ 10 A	200 $\mu$ A ~ 10 A	200 $\mu$ A ~ 10 A
AC current	60 mA ~ 10 A	20 mA ~ 10 A	200 $\mu$ A ~ 10 A
Scanner card	Not support	Support	Support
Display	4.3" TFT-LCD, 480*272		



### Service Promise:

Since the date of purchase, we offer three year’s warranty for the main unit:

- During the warranty period, if the products cause any hardware or software failure because of the quality, Siglent's after-sales service center or Siglent's designated maintenance points will offer the maintenance of the fault products for the user.
- Because of improper use or any other artificial reason, the damage won't be included in the free maintenance.

### 1. Extension after-sales service

Extension service is based on the main unit (not including accessories) as an object. During the extension service, Siglent still offer free maintenance after the standard warranty period.

#### 1.1 Three advantages:

- Guarantee investment. To extend the life cycle of the products.
- Save money. To prevent the high cost of maintenance after the warranty period.
- Avoid the repeated investment. To prevent buying new equipments because it can't be repaired after the warranty period.

#### 1.2 The content of the extension service

You can buy the following extension service according to your demand:

Solution	Viability	Instruction
ES4	One year after the warranty period	According to the service terms, Siglent will offer another one year for the after-sales maintenance service
ES5	Two years after the warranty period	According to the service terms, Siglent will offer another two years for the after-sales maintenance service

### 2. Calibration services

After long-term use, oscilloscope will cause the deviation of measured value and waveform display, because of its work temperature and humidity. Siglent will restore the original performance and accuracy of factory setting to calibrate the deviation.

- Eliminate the error of measurement
- Restore the original performance and accuracy of the factory setting to the “new” state
- The upgrade of the firmware and the software
- Make the instruments comply with the standard of the ISO9001 quality management process
- Traceable calibration certificates





**Follow us on Facebook:  
SiglentTech**

modification date: 2024-05

**Headquarters:**

SIGLENT Technologies Co., Ltd  
Add: Bldg No.4 & No.5, Antongda Industrial  
Zone, 3rd Liuxian Road, Bao'an District,  
Shenzhen, 518101, China  
Tel: + 86 755 3688 7876  
Fax: + 86 755 3359 1582  
Email: sales@siglent.com  
Website: int.siglent.com

**USA:**

SIGLENT Technologies America, Inc  
6557 Cochran Rd Solon, Ohio 44139  
Tel: 440-398-5800  
Toll Free: 877-515-5551  
Fax: 440-399-1211  
Email: info@siglent.com  
Website: www.siglentna.com

**Europe:**

SIGLENT Technologies Germany GmbH  
Add: Staetzlinger Str. 70  
86165 Augsburg, Germany  
Tel: +49(0)-821-666 0 111 0  
Fax: +49(0)-821-666 0 111 22  
Email: info-eu@siglent.com  
Website: www.siglenteu.com

Every Bench. Every Engineer. Every Day.